

3325335COM Night Stand

Date of Purchase ___ / ___ / ___
Lot Number:

B343325335COM2

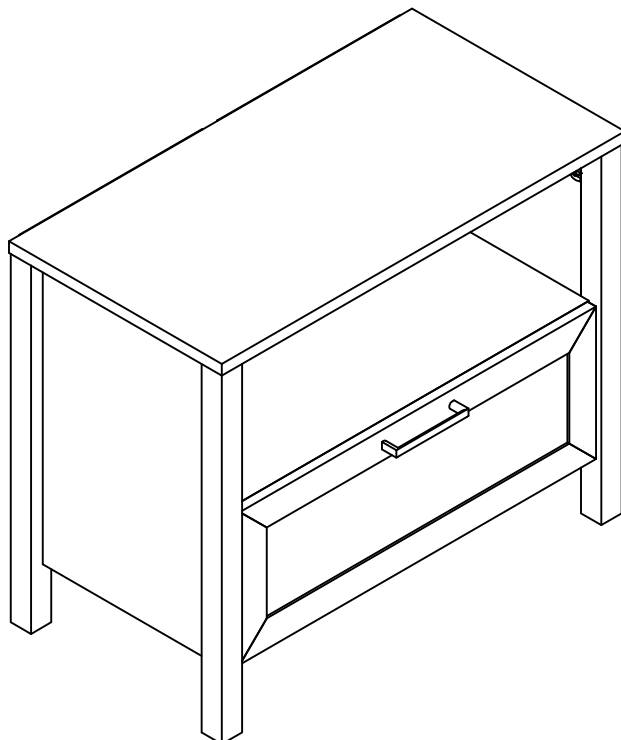

Do Not Return This Product!

Contact our customer service team for help first.

Call: 1-800-489-3351 (toll free)

Monday-Friday 9am - 5pm CST

Visit: www.ameriwoodhome.com

THIS INSTRUCTION BOOKLET CONTAINS **IMPORTANT** SAFETY INFORMATION. PLEASE READ AND KEEP FOR FUTURE REFERENCE.

Keep your home and family safe with the wall anchor kit that is included with the product.

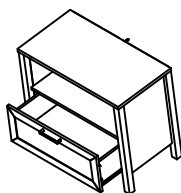

Serious or fatal crushing injuries can occur from tipping furniture.

WARNING: Manufacturer assumes no liability for improper installation or excessive loads placed on screws or bracket. This wall anchor is not a substitute for proper adult supervision.

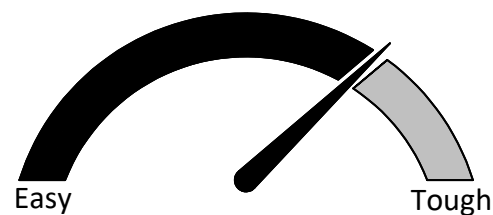

Assembly Difficulty Meter

Contact Us!

Do NOT return this product!

Contact our friendly customer service team first for help.

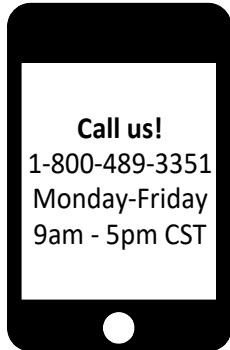

Visit ameriwoodhome.com to view the limited warranty valid in the U.S. and Canada.

Assembly Tips



Helpful Hints

PEOPLE NEEDED FOR ASSEMBLY: **1-2**
ESTIMATED ASSEMBLY TIME: **2 HOURS**

- Open your item in the area you plan to keep it to avoid excessive heavy lifting.
- Identify, sort and count the parts before attempting assembly.
- Compression dowels are lightly tapped in with a hammer.
- Slides are labeled with a **R** (right) and **L** (left) for proper placement.
- Make sure to always face the point on the top of the Cam Lock towards the outer edge.
- Use all the nails provided for the back panel and spread them out equally.
- Back panel must be used to make sure your unit is sturdy.
- Do NOT use harsh chemicals or abrasive cleaners on this item.
- Never push, pull, or drag your furniture.



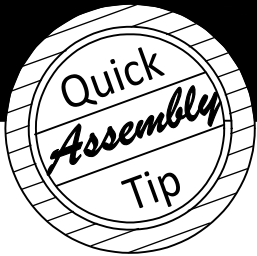

Before You Start

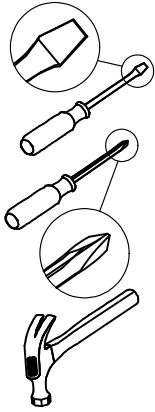

- ✓ Read through each step carefully and follow the proper order
- ✓ Separate and count all your parts and hardware
- ✓ Give yourself enough room for the assembly process
- ✓ Have the following tools: Flat Head Screwdriver, #2 Phillips Head Screwdriver and Hammer
- ✓ Caution: If using a power drill or power screwdriver for screwing, please be aware to slow down and stop when screw is tight. Failure to do so may result in stripping the screw.

Cam Lock Fastening System

This Cam Lock Fastening System will be used throughout the assembly process.

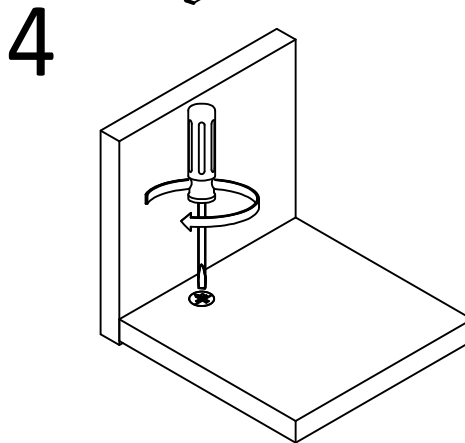
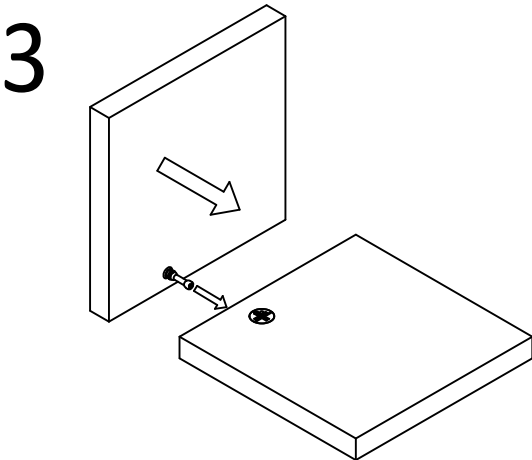
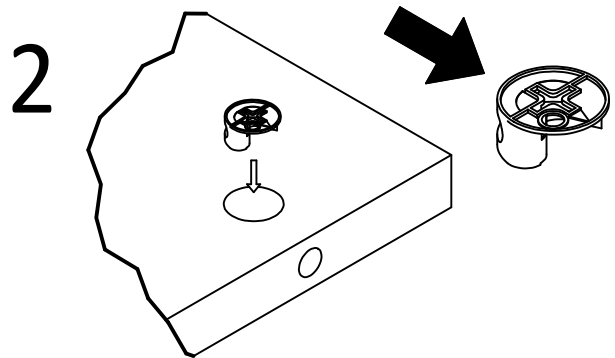
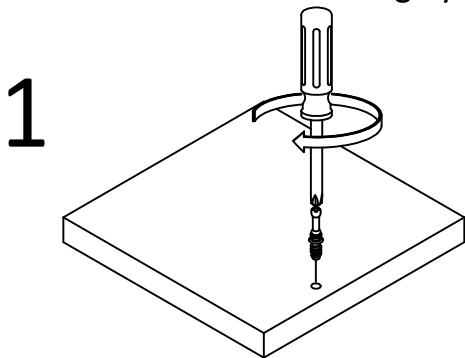

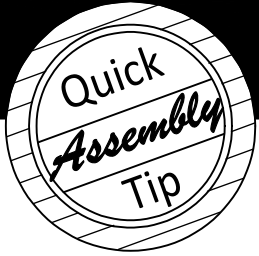

Before You Start

Please Note:

You may need to lightly tap the wood dowels to insert into the holes during your assembly process.

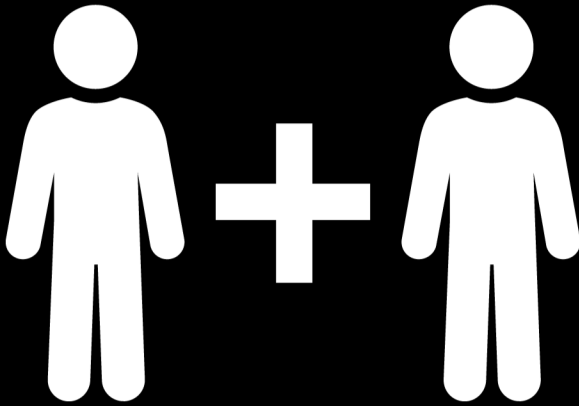
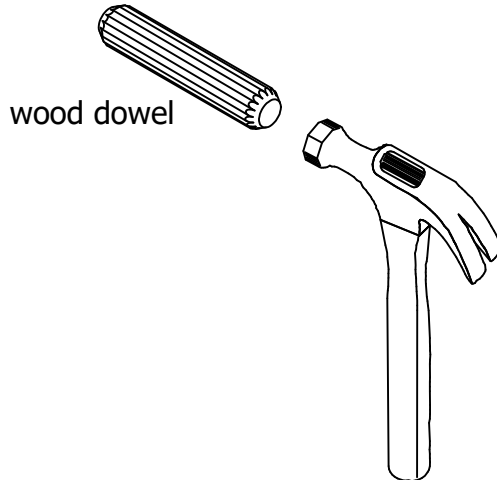

2 PEOPLE NEEDED FOR ASSEMBLY

**2 PERSONAS NECESITADAS
PARA LA ASAMBLEA**

**2 PERSONNES NÉCESSAIRES
POUR L'ASSEMBLAGE**

CAUTION: Failure to use 2 people for assembly could result in unit damage or personal injury.

PRECAUCIÓN: Si no se utilizan 2 personas para el ensamblaje, se pueden producir daños en la unidad o lesiones personales.

ATTENTION: Échec d'utiliser 2 personnes pour l'assemblage peut causer du dommage au meuble ou causer des blessures.

Board Identification

Not actual size

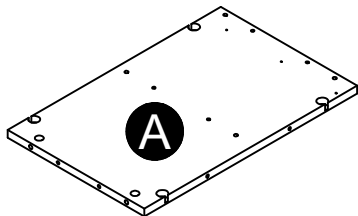

Left Panel
33325335010

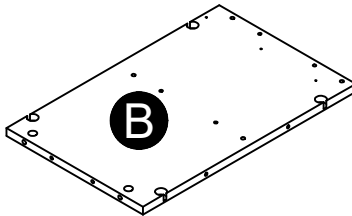

Right Panel
33325335020

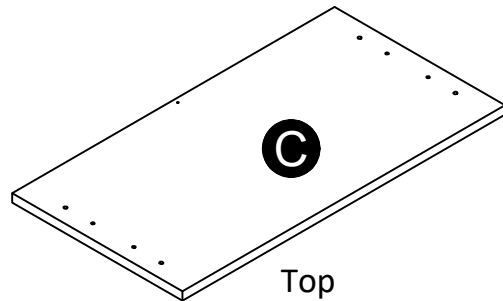

Top
33325335031

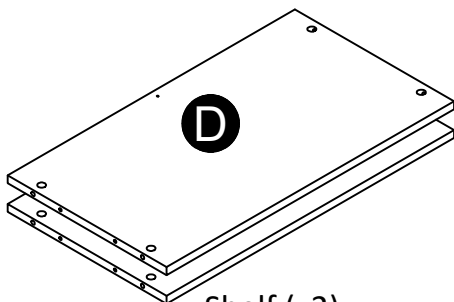

Shelf (x2)
33325335041

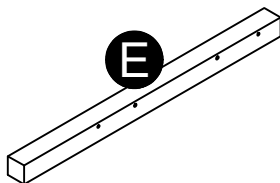

Left Front Leg
33325335050

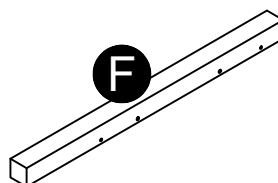

Right Front Leg
33325335060

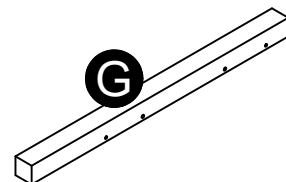

Left Rear Leg
33325335070

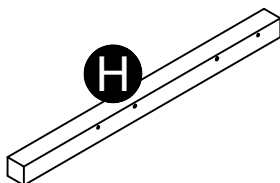

Right Rear Leg
33325335080

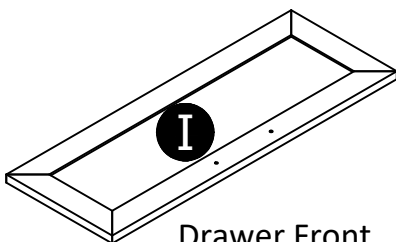

Drawer Front
33325335090

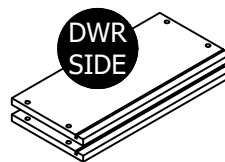

Drawer Side (x2)
39991167346200C

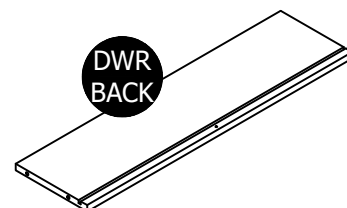

Drawer Back
39991167062090B

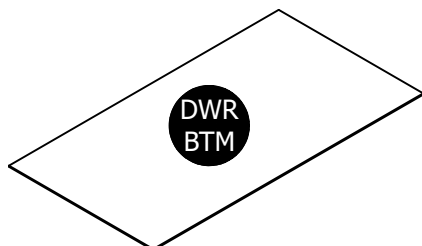

Drawer Bottom
39991338063110D

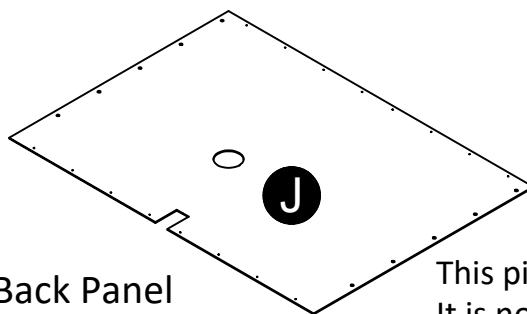

Back Panel
K332533501

This piece is paperboard construction. It is not made from wood, but is required for the assembly of your unit.

Board Identification

Not actual size

This piece is paperboard construction.
It is not made from wood, but is
required for the assembly of your unit.

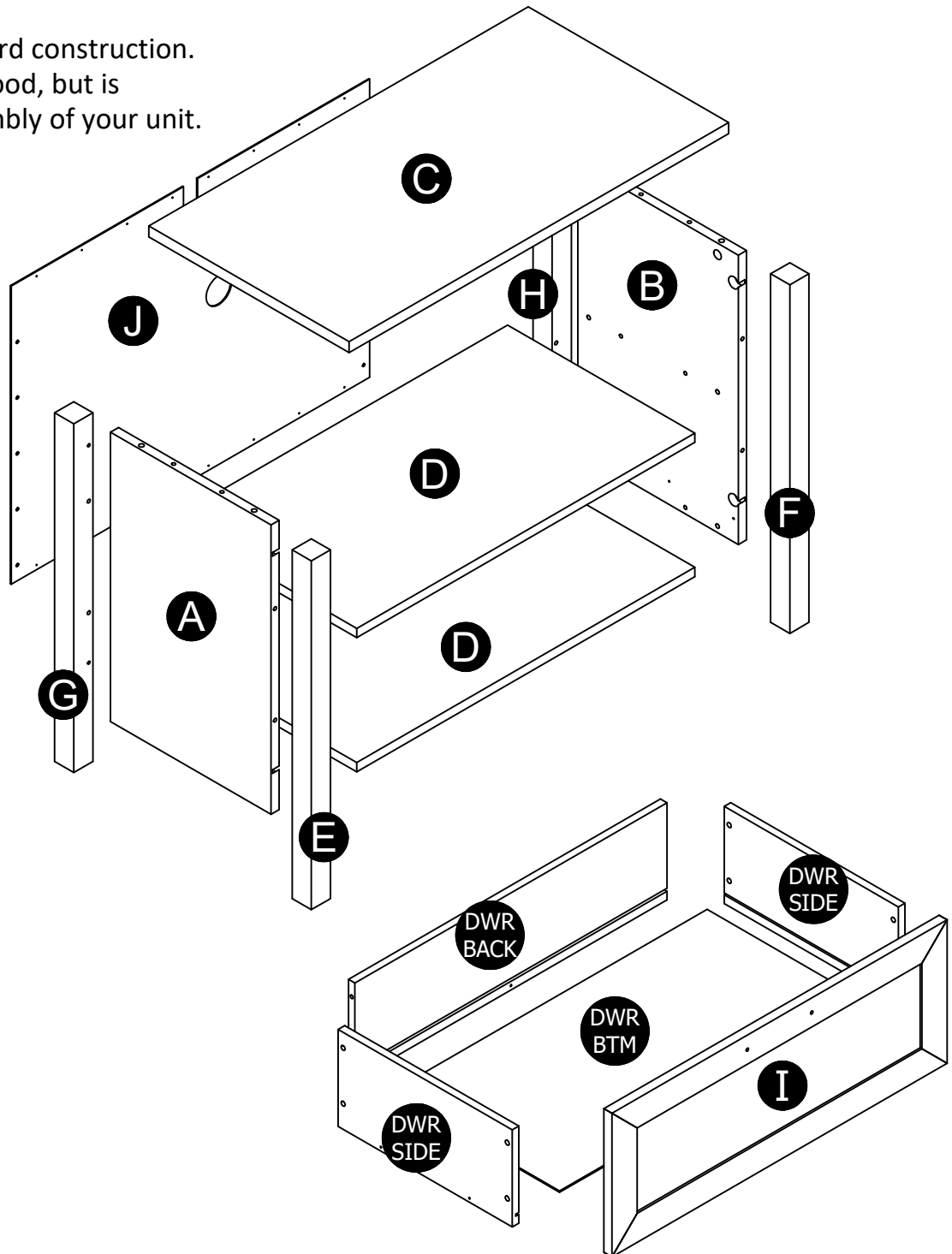

Part List

Actual Size

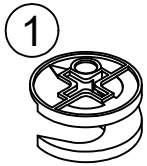

(x12)
#A22620
cam lock

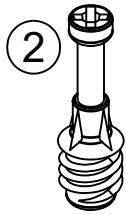

(x12)
#A22610
cam bolt



(x10)
#A11080
#6 x 7/16" screw

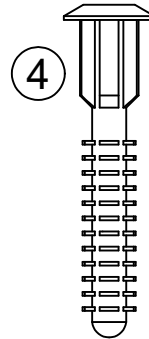

(x4)
#A21970
drive fastener



(x20)
#A12120
#8 x 7/16" screw



(x8)
#A22910
connector bolt

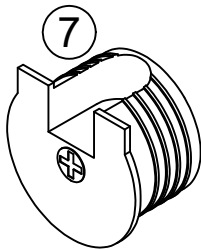

(x8)
#A22920
connector

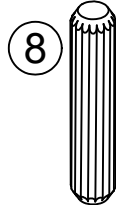

(x20)
#A21660
wood dowel



(x2)
#A17400
8-32 x 7/8" truss

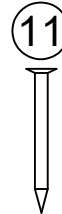

(x16)
#A21110
nail

Part List

Not Actual Size

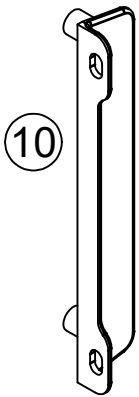

(x2)
#A54520
drawer bracket

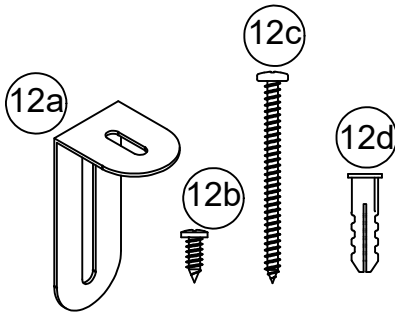

(x1)
#A84050
safety bracket kit



Left Cabinet Member



Right Cabinet Member

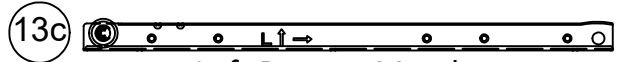

Left Drawer Member

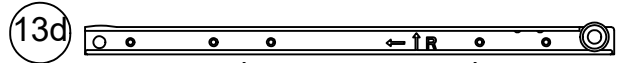

Right Drawer Member

(x1)
#A56750
drawer slide pkg.

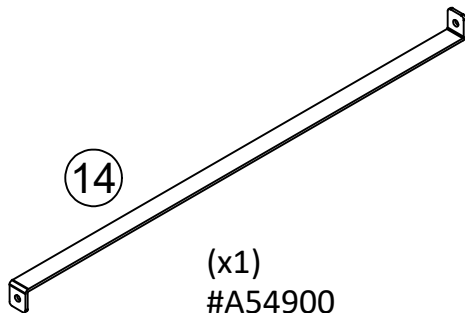

(x1)
#A54900
drawer brace

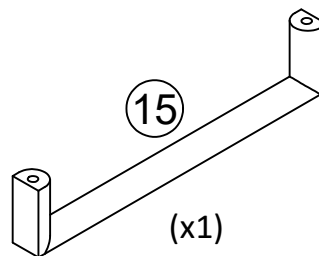

(x1)
#A51715
handle

STEP 1

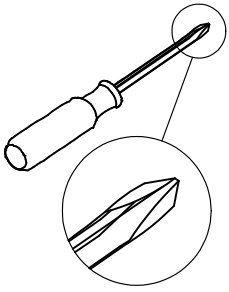

6
(x8)
#A22910

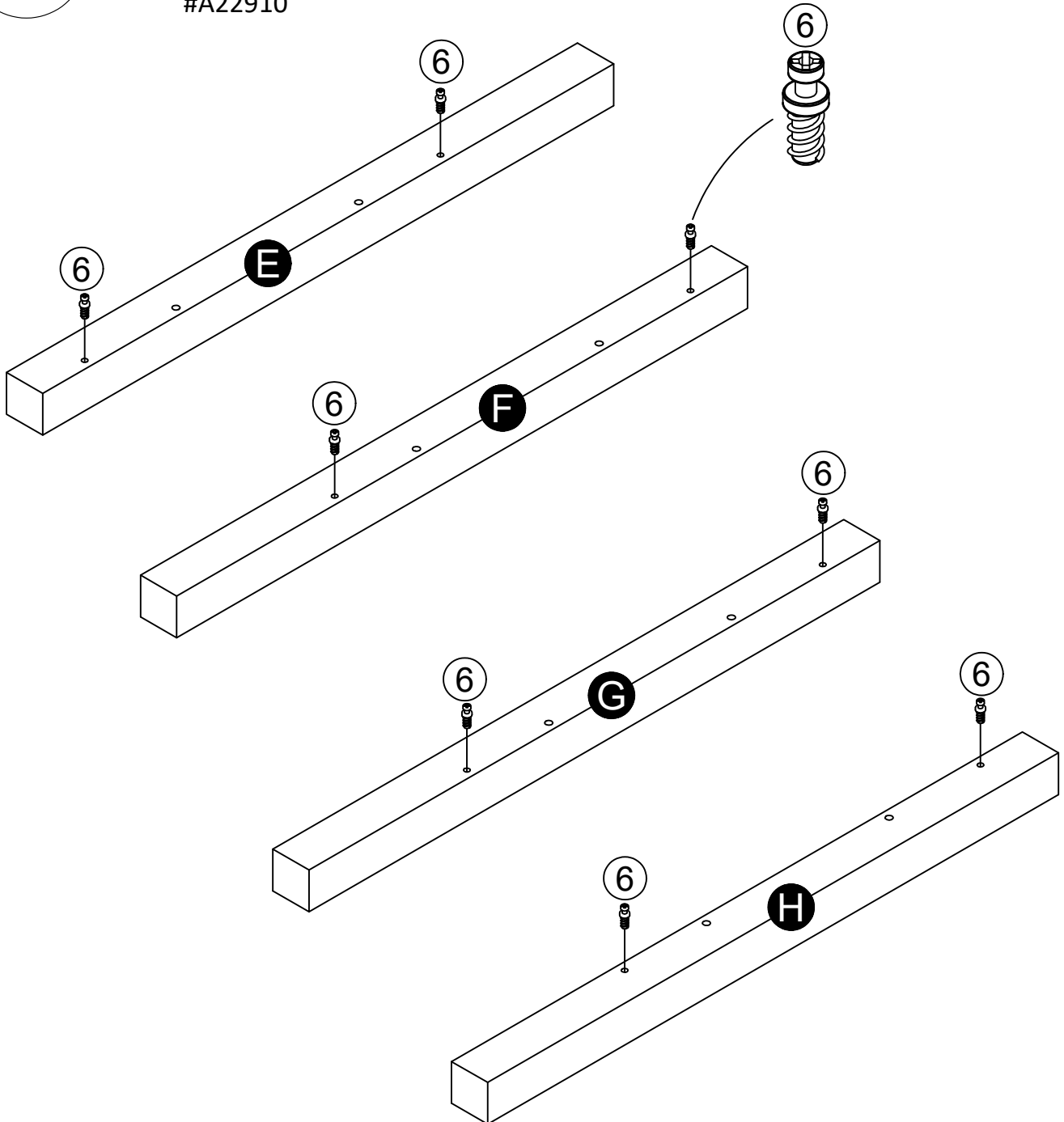

STEP 3

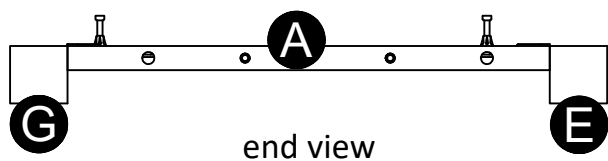
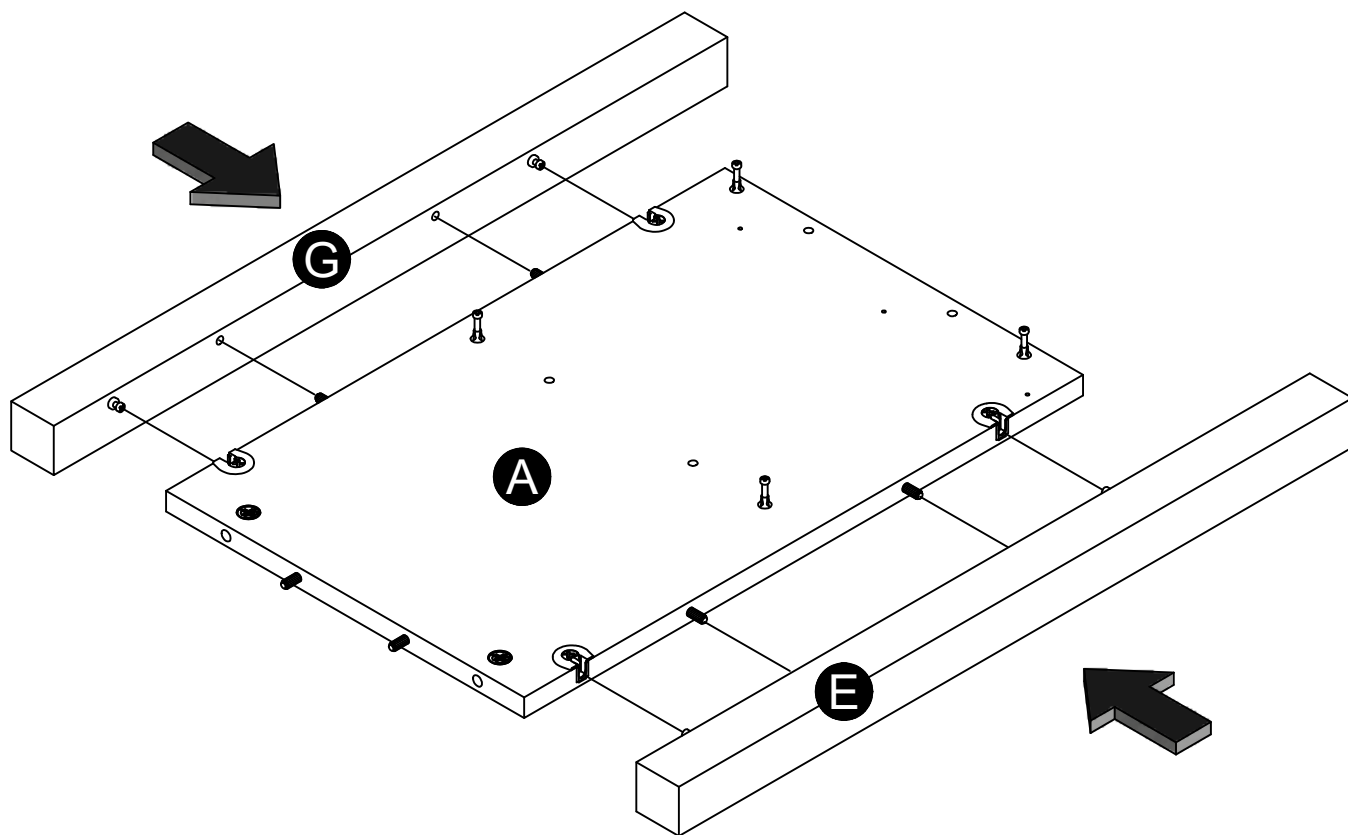
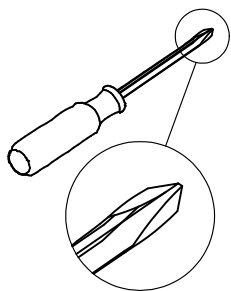

end view

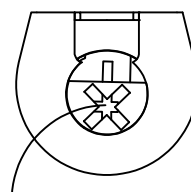

Turn screw clockwise
to lock in place.

STEP 4

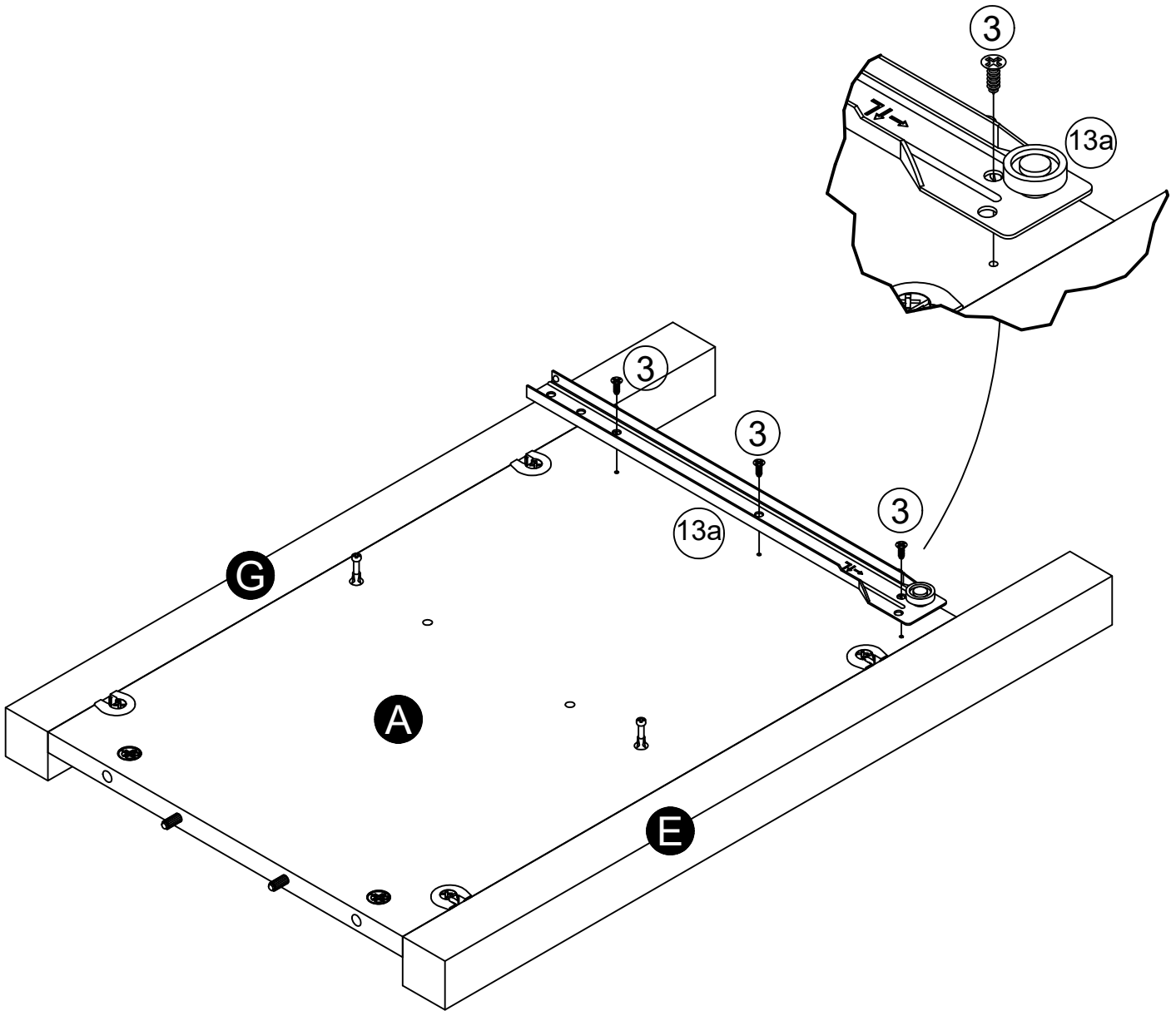
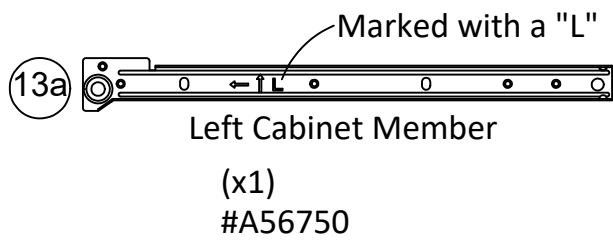
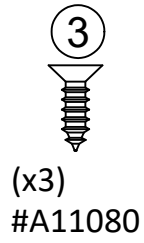
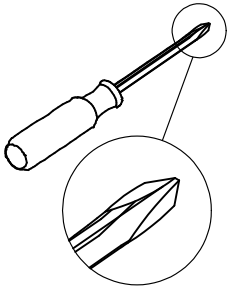

STEP 5

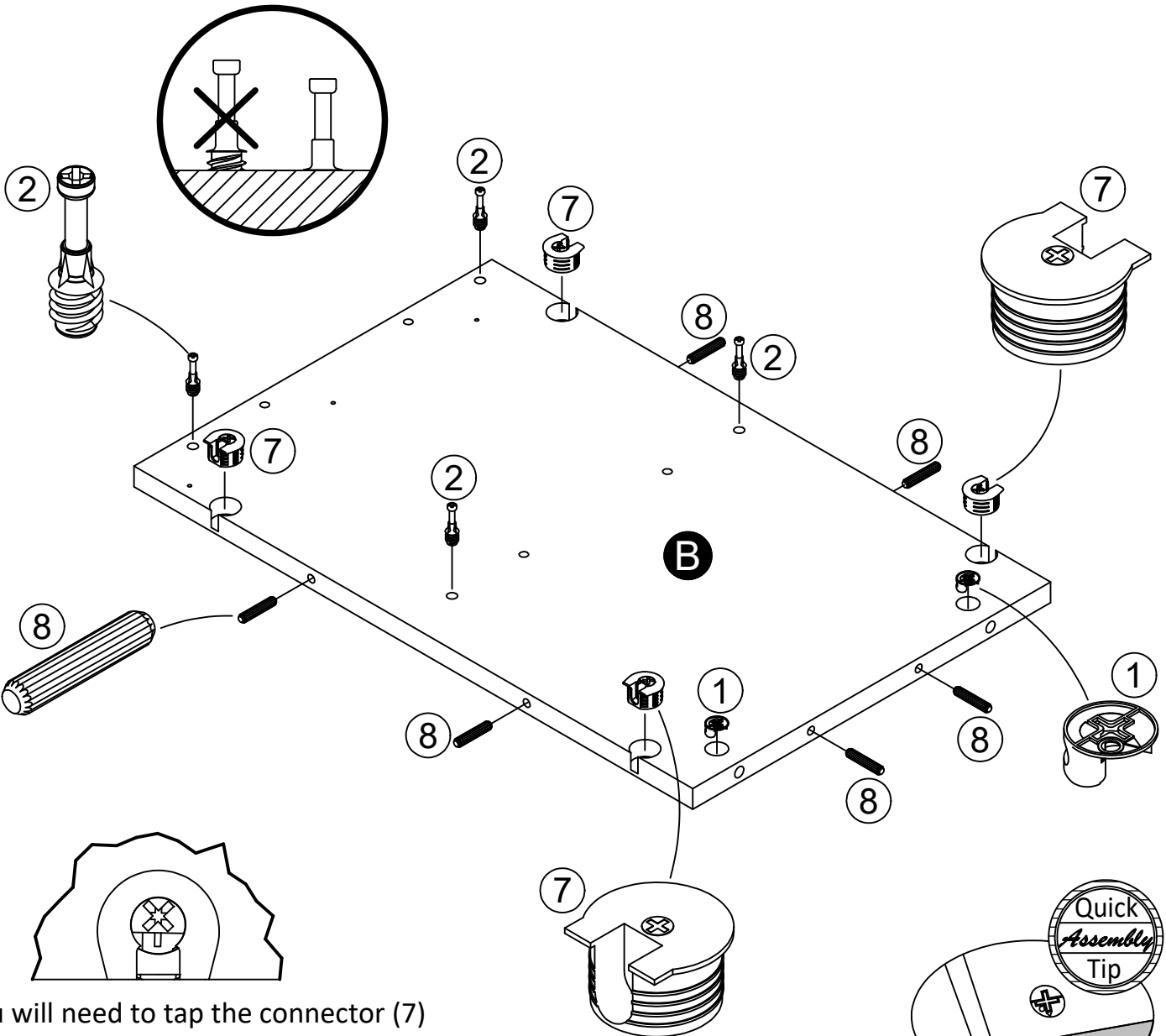
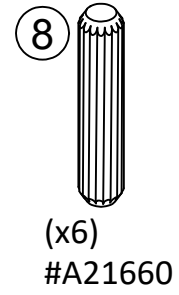
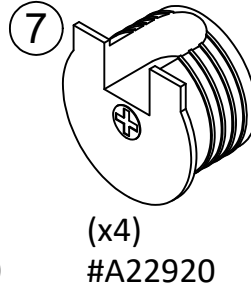
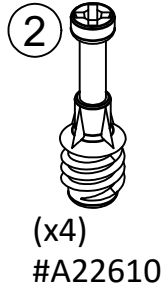
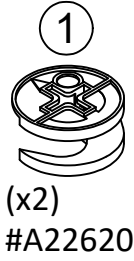
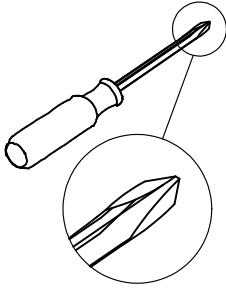
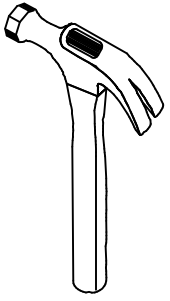

You will need to tap the connector (7) with a hammer to fully insert. Be sure the connector is positioned as shown before tapping into hole.

Proper orientation of CAM LOCK

STEP 6

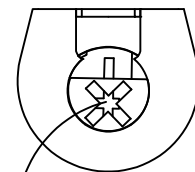
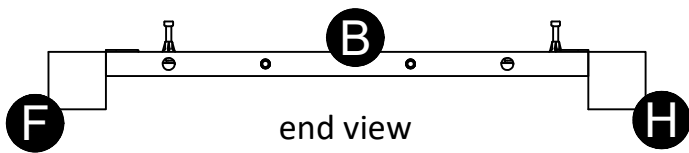
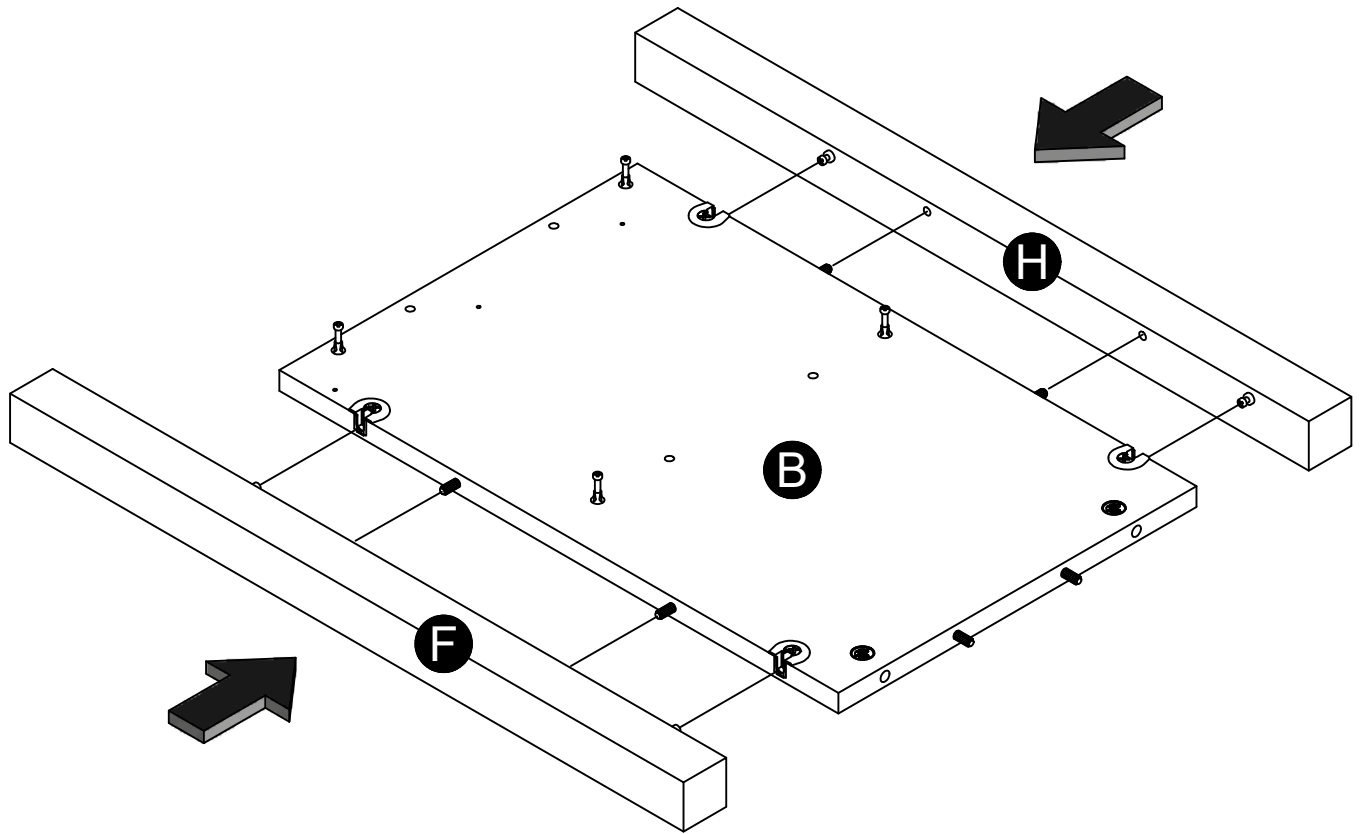
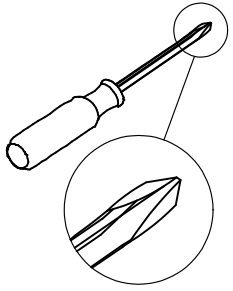

Turn screw clockwise to lock in place.

STEP 7

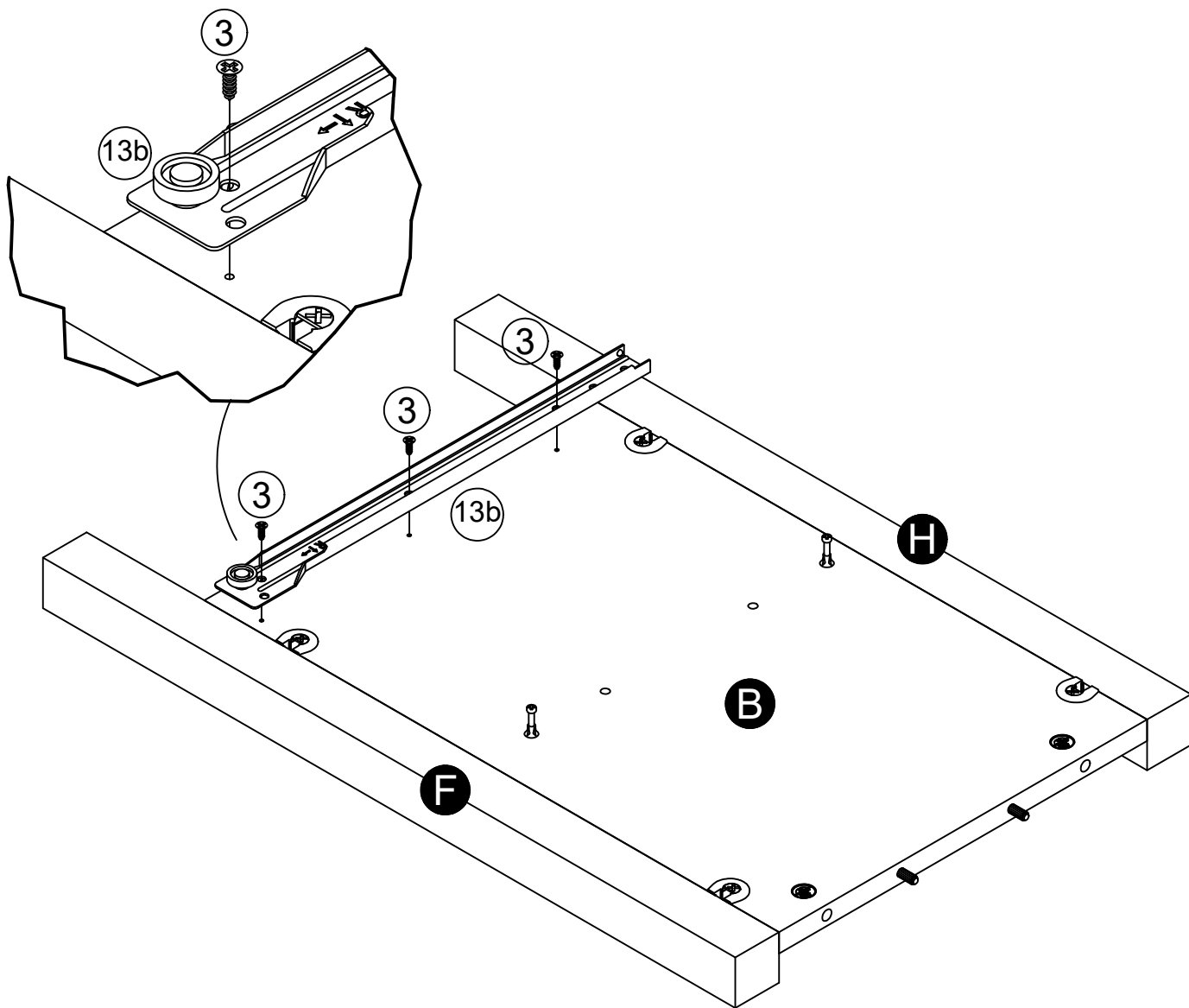
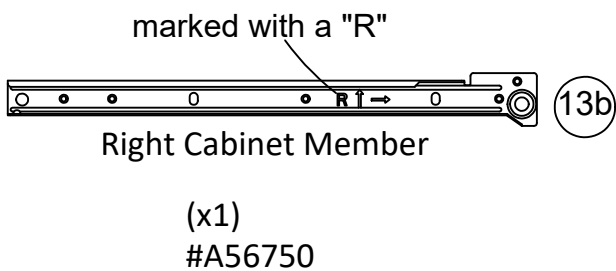
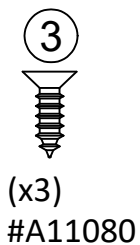
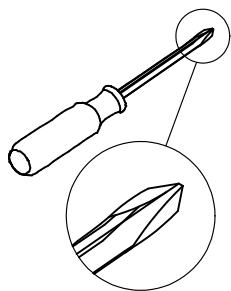

STEP 8

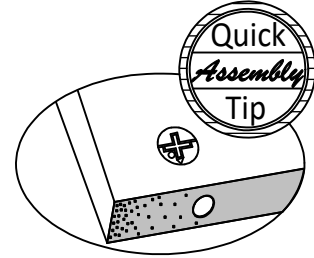
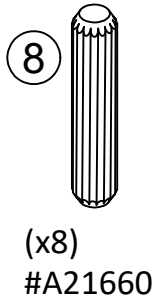
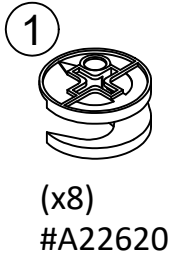

Proper orientation of CAM LOCK

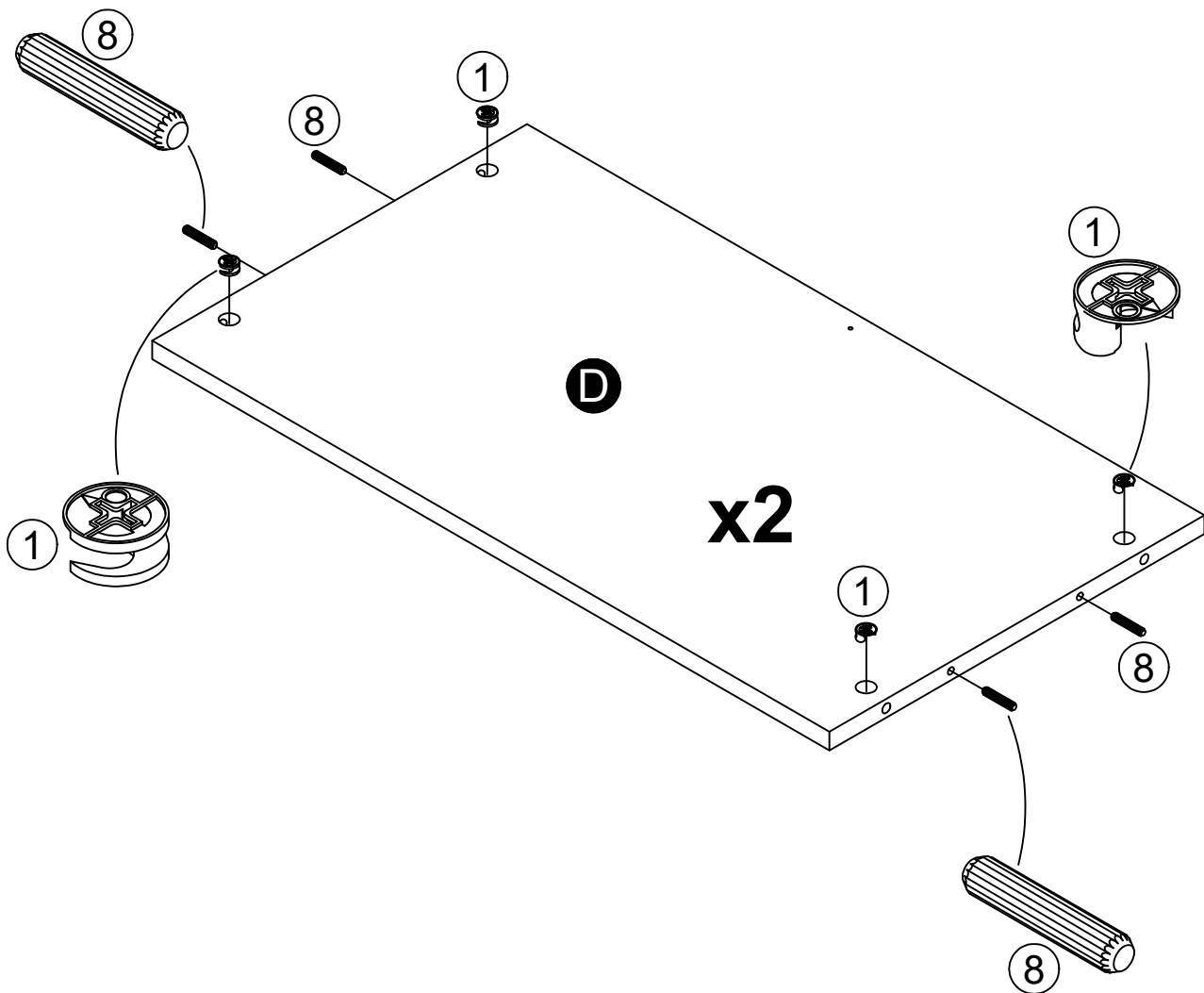

STEP 9

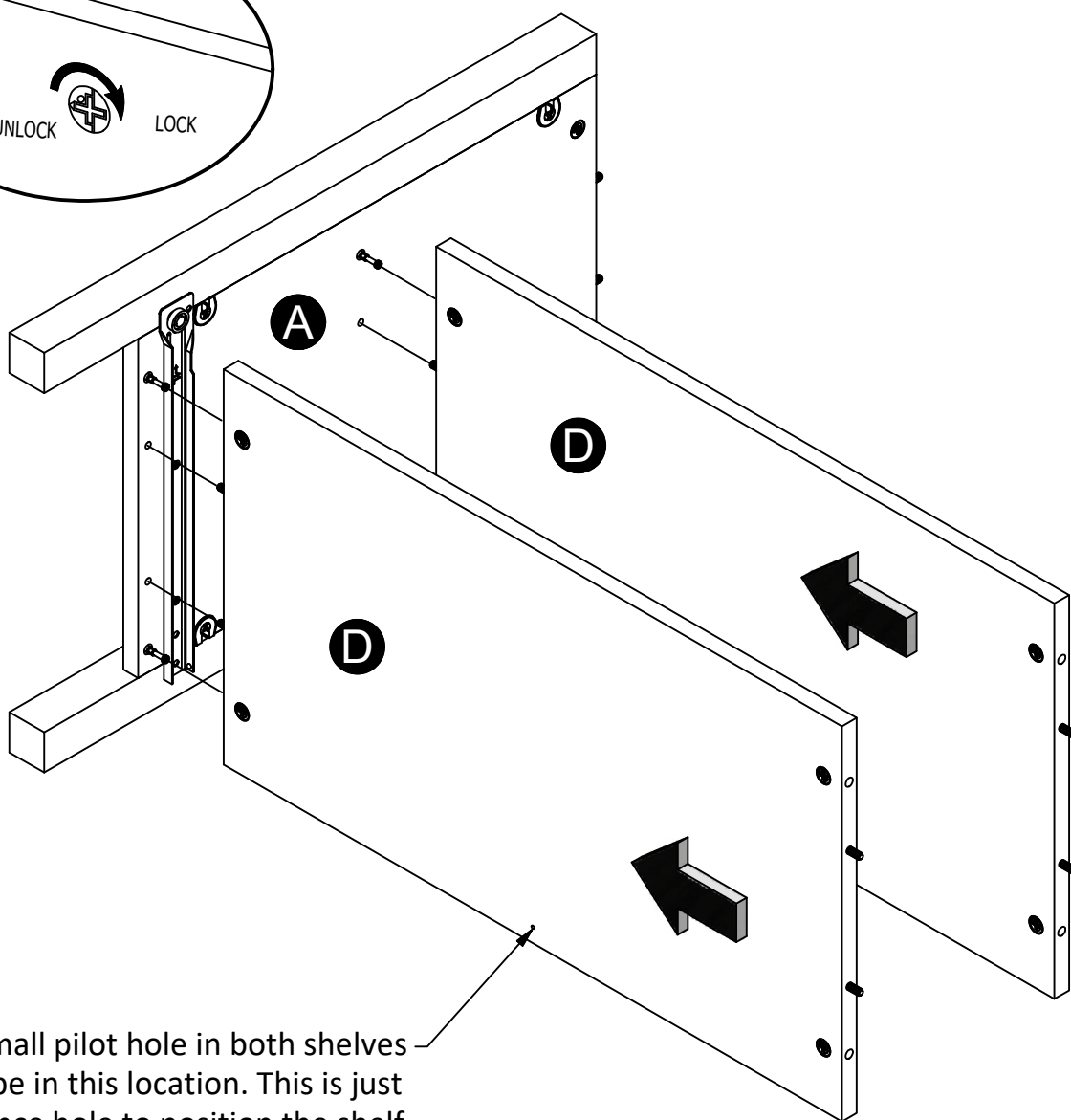
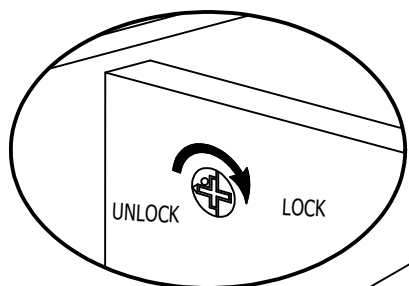
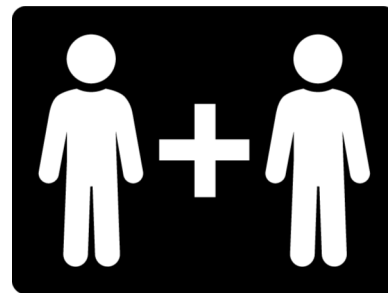
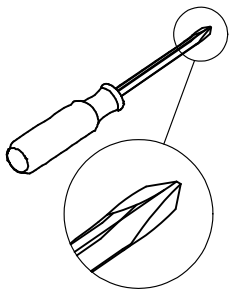

Note: Small pilot hole in both shelves (D) will be in this location. This is just a reference hole to position the shelf correctly.

STEP 10

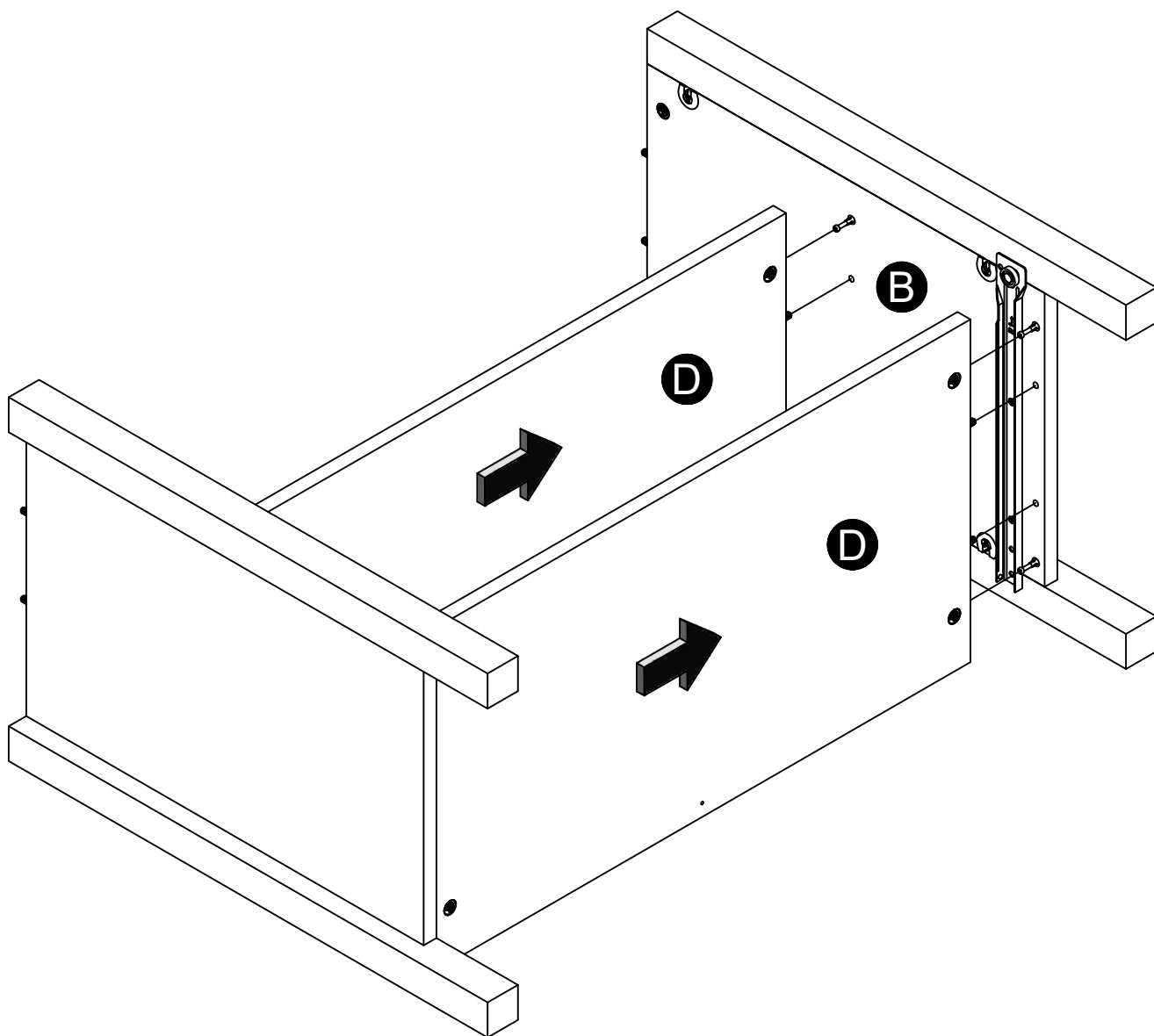
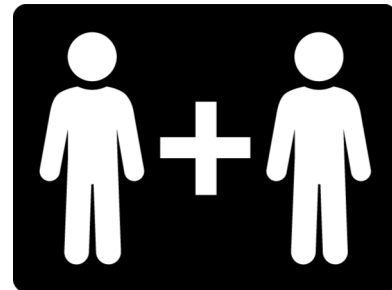
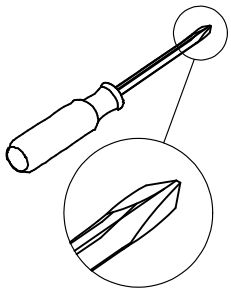

STEP 11

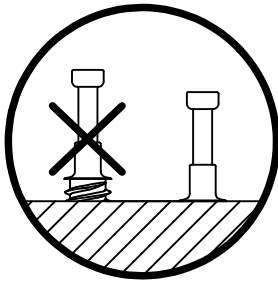
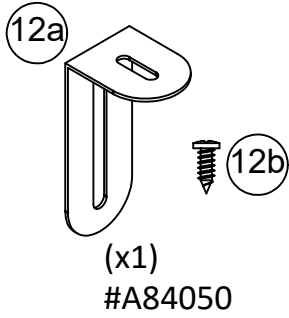
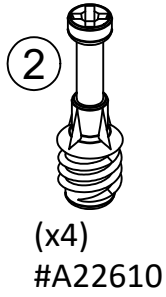
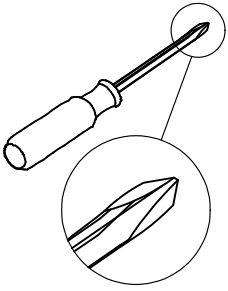

Do not fully
tighten screw.

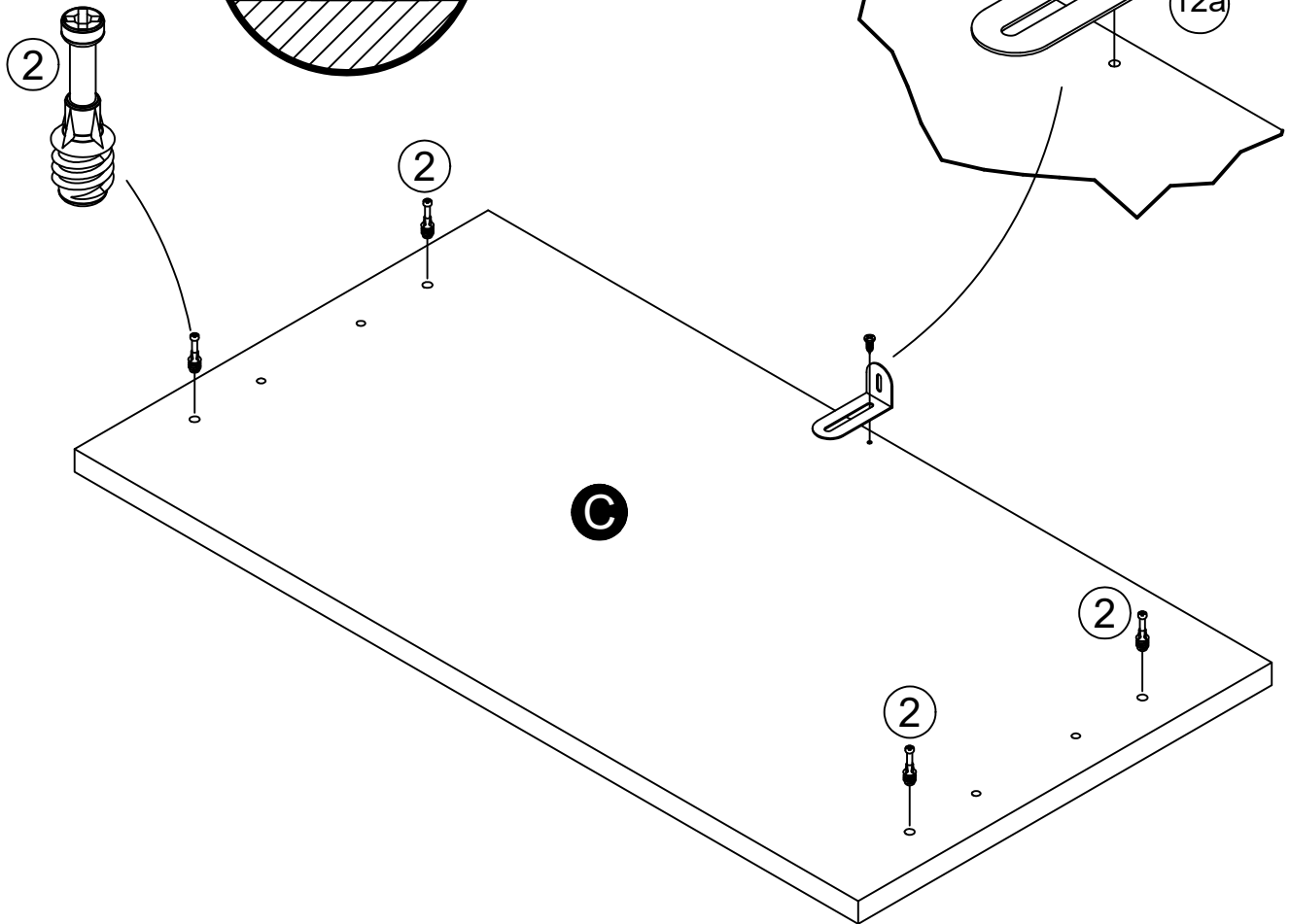

STEP 12

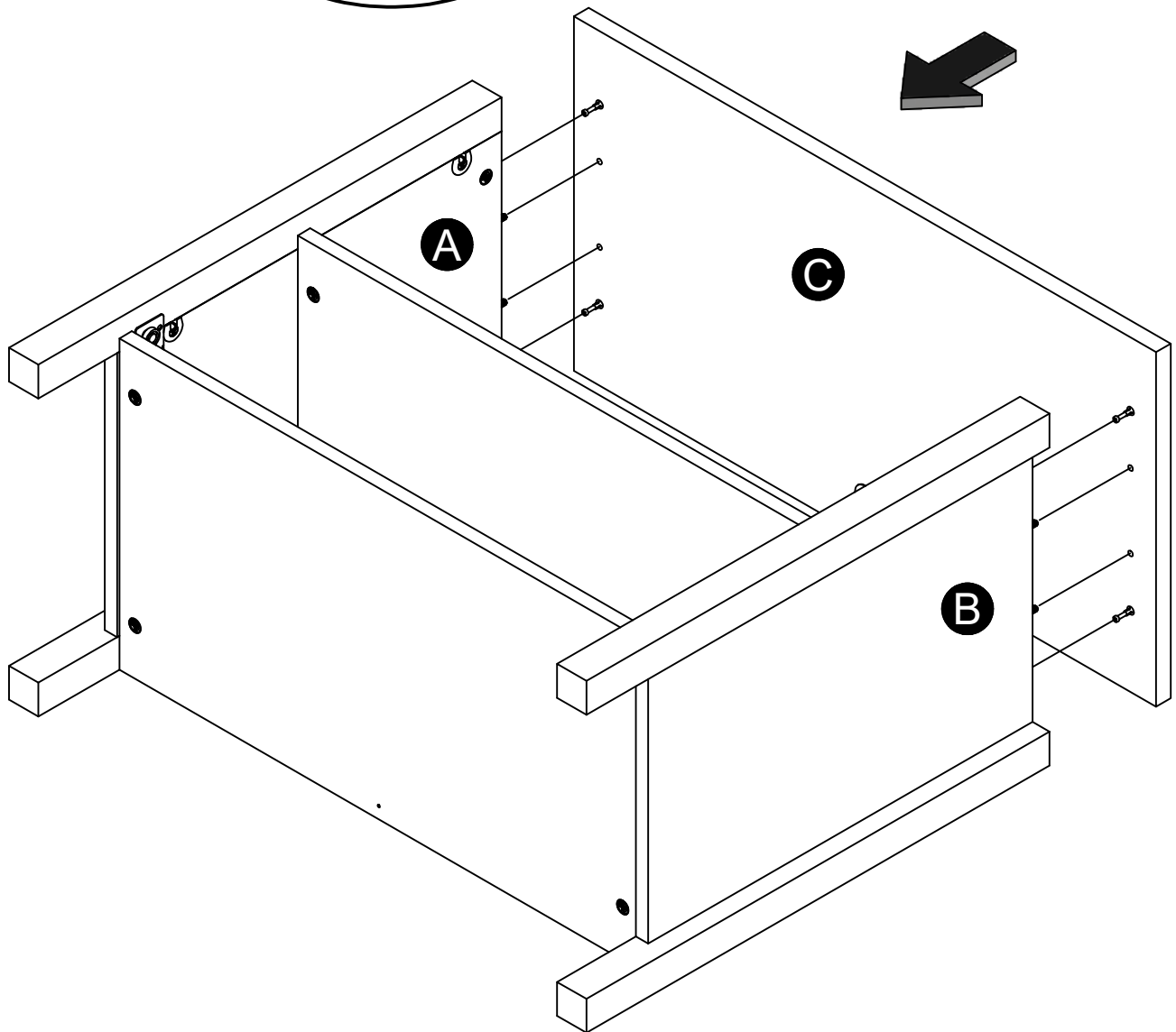
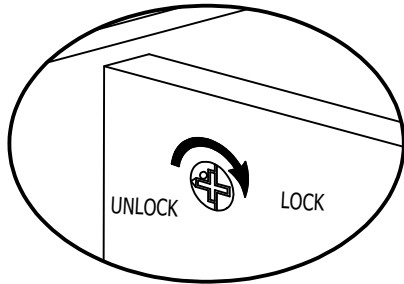
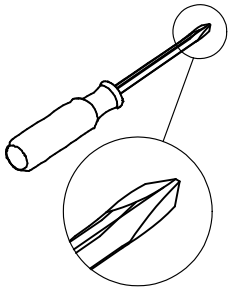

STEP 13

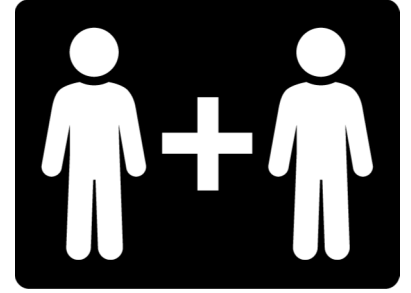
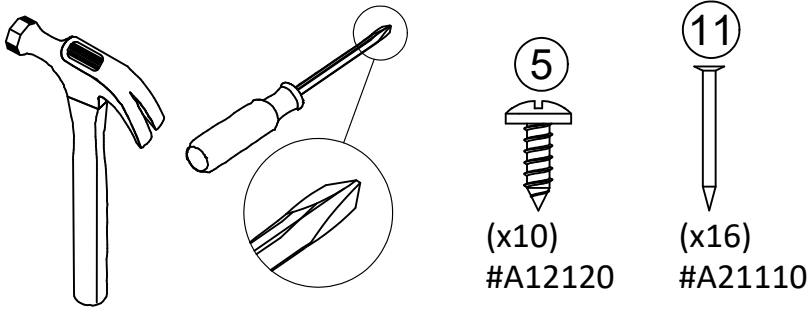

IMPORTANT! THE BACK PANEL IS A STRUCTURAL PART OF THIS UNIT AND MUST BE INSTALLED PROPERLY.

With the help of another person, turn the unit over on its front side. Position back panel as shown. Align squarely with outer edges. Attach back panel to rear legs (G&H) with screws (5) but do not tighten. Flush bottom edge of back panel with bottom edge of the bottom and nail straight into back edges of top (C) and bottom (D). Now tighten the screws (5).

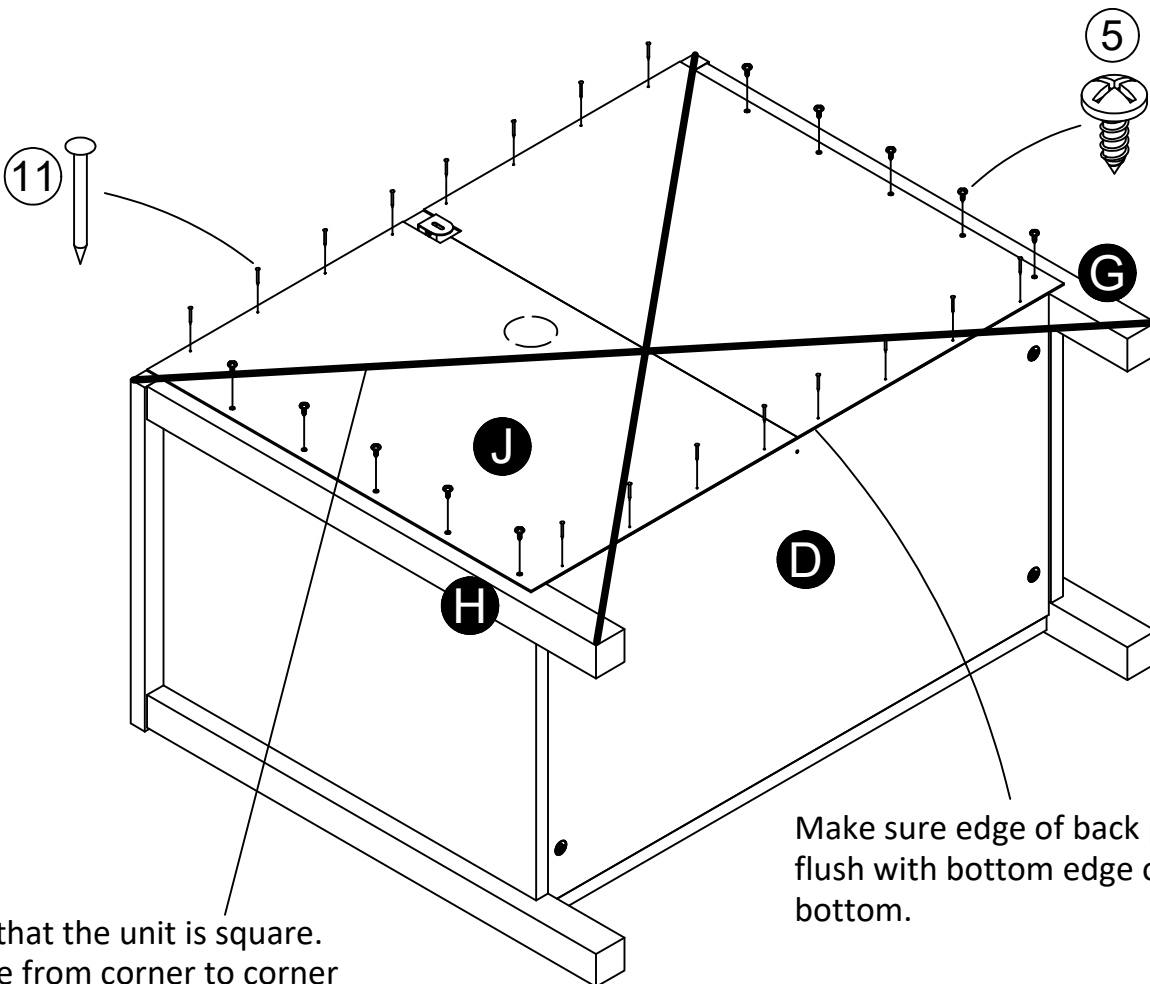

Assure that the unit is square.
Distance from corner to corner
must be equal as shown.

Make sure edge of back panel is
flush with bottom edge of the
bottom.

STEP 14

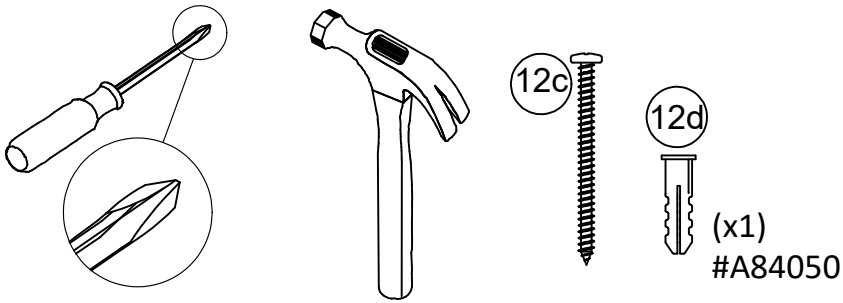

For Masonry, Concrete, or other wall materials:
Consult your local hardware store for appropriate anchors to securely attach the safety bracket.

IMPORTANT: THIS UNIT MUST BE SECURE TO THE WALL TO HELP PREVENT TIPOVER. FOLLOW THESE INSTRUCTIONS TO INSTALL THE ANTI-TIPPING SAFETY BRACKET PROVIDED WITH THIS PRODUCT.

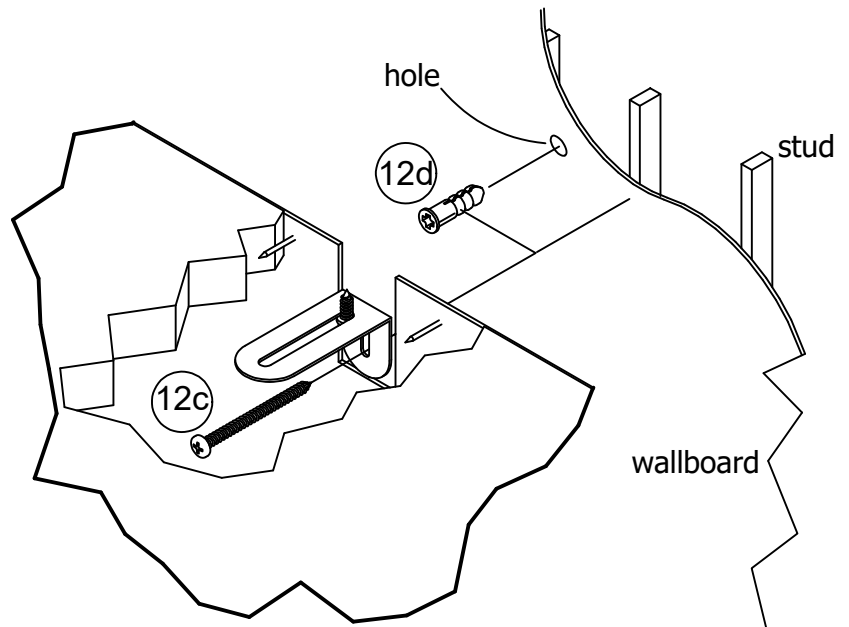

OPTION 1: Attachment into a wall stud (preferred method)

Using a stud finder, locate a stud in the wall. Place your unit against the wall, with the safety bracket aligned in this location. To make driving the screw easier, you can drill a 1/8" diameter pilot hole (3mm) through the safety bracket into the stud. Drive the screw through the safety bracket into the wall stud. Tighten the screw that was not fully tightened in step 11.



OPTION 2: Attachment into drywall

Locate your unit where desired against a wall and mark the wall through the safety bracket, then move your unit aside. Drill a 3/16" diameter hole (5mm) into the wallboard. Tap the wall anchor into the hole until it is flush. Move your unit into location and fasten the wall bracket to the wall anchor with the screw. Tighten the screw that was not fully tightened in step 11.

⚠ WARNING	
	<p>Children have died from furniture tip over. To reduce the risk of furniture tip over:</p> <ul style="list-style-type: none">• ALWAYS install tip over restraint provided.• NEVER put a TV on this product.• NEVER allow children to stand, climb or hang on drawers, doors, or shelves.• NEVER open more than one drawer at a time.• Place heaviest items in the lowest drawers.
	

STEP 15

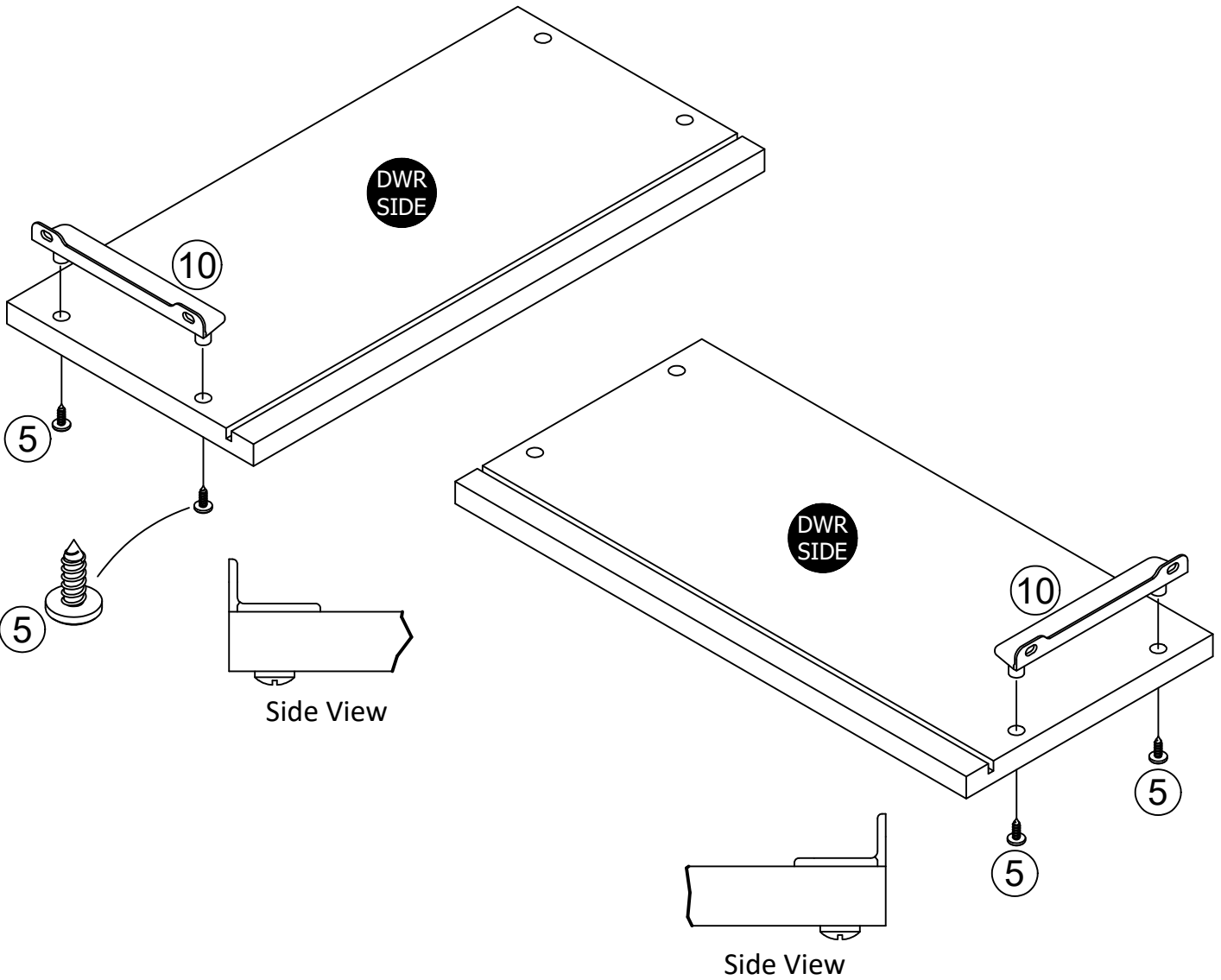
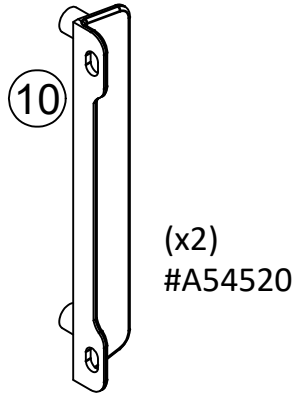
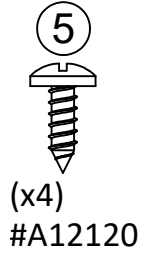
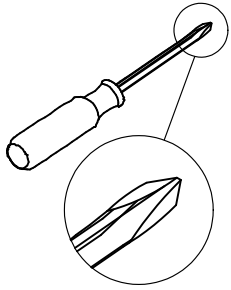

STEP 16

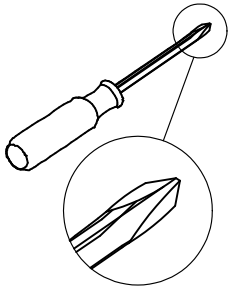

5
(x4)
#A12120

Be sure the grooves in the drawer sides are centered with the groove in the drawer front.

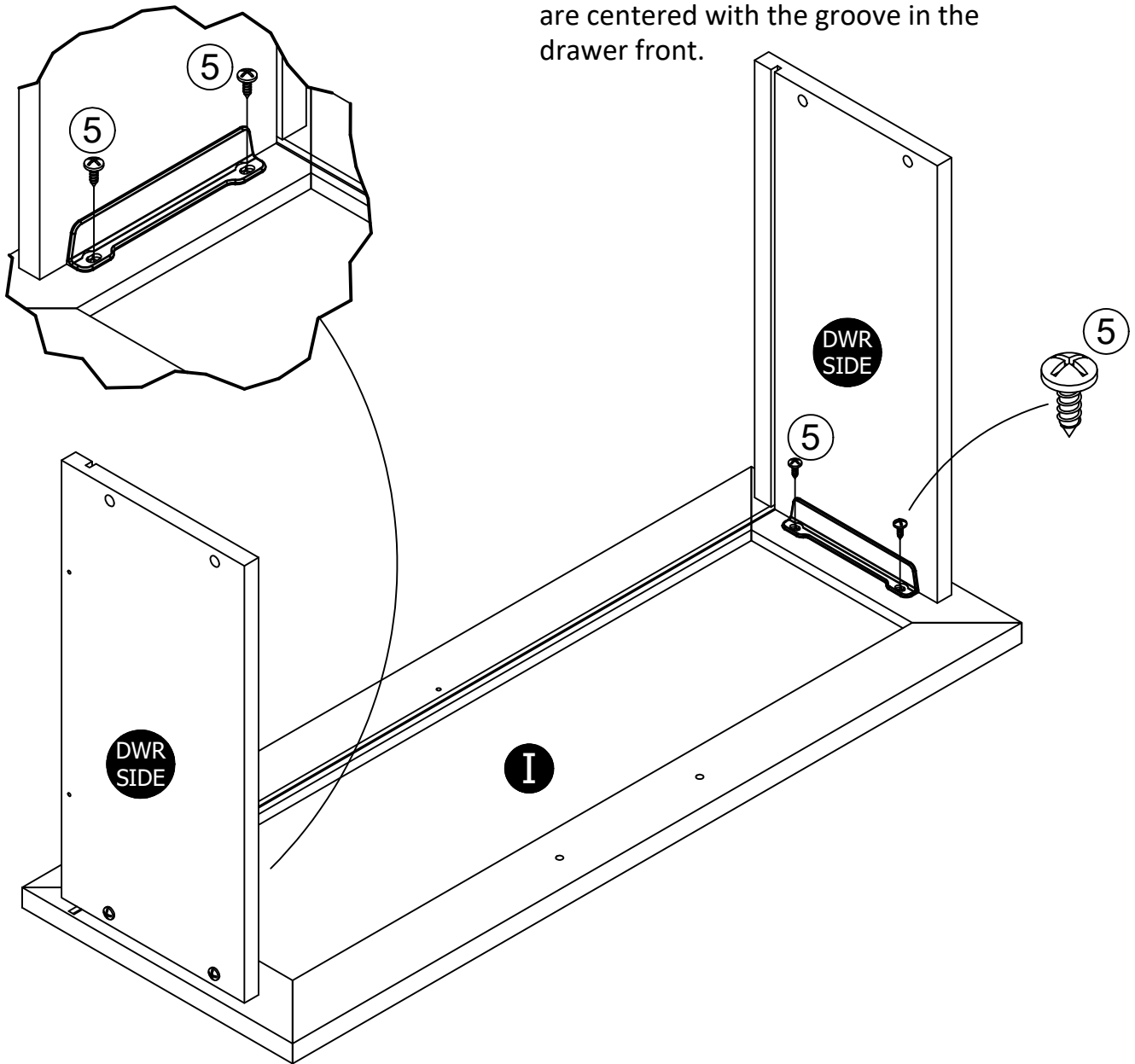

STEP 17

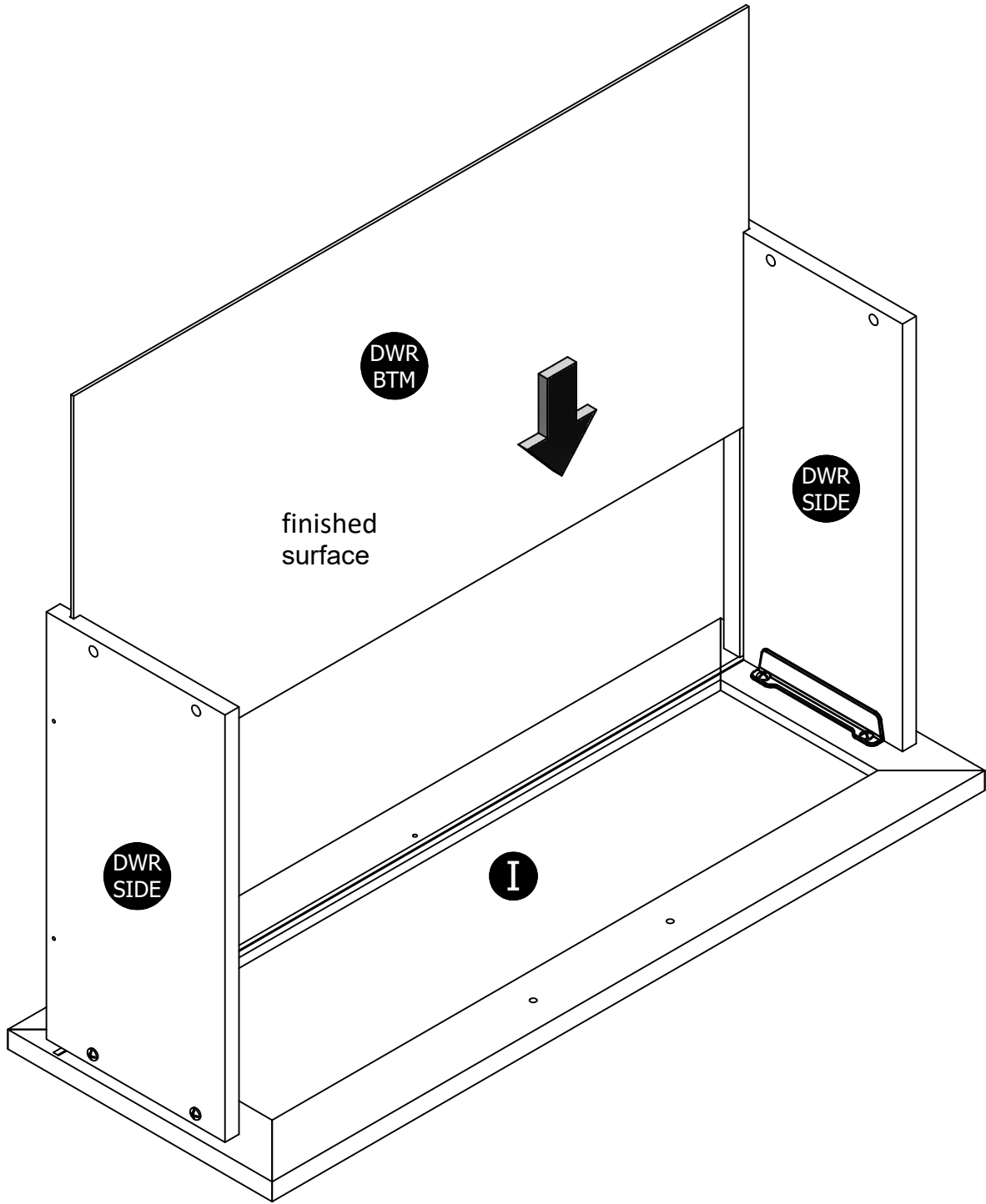

STEP 18

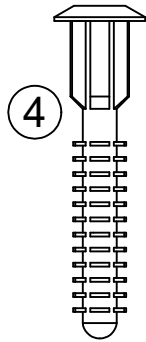

4

(x4)
#A21970

Note: You will need to tap the drive fasteners (4) with a hammer to securely fasten.

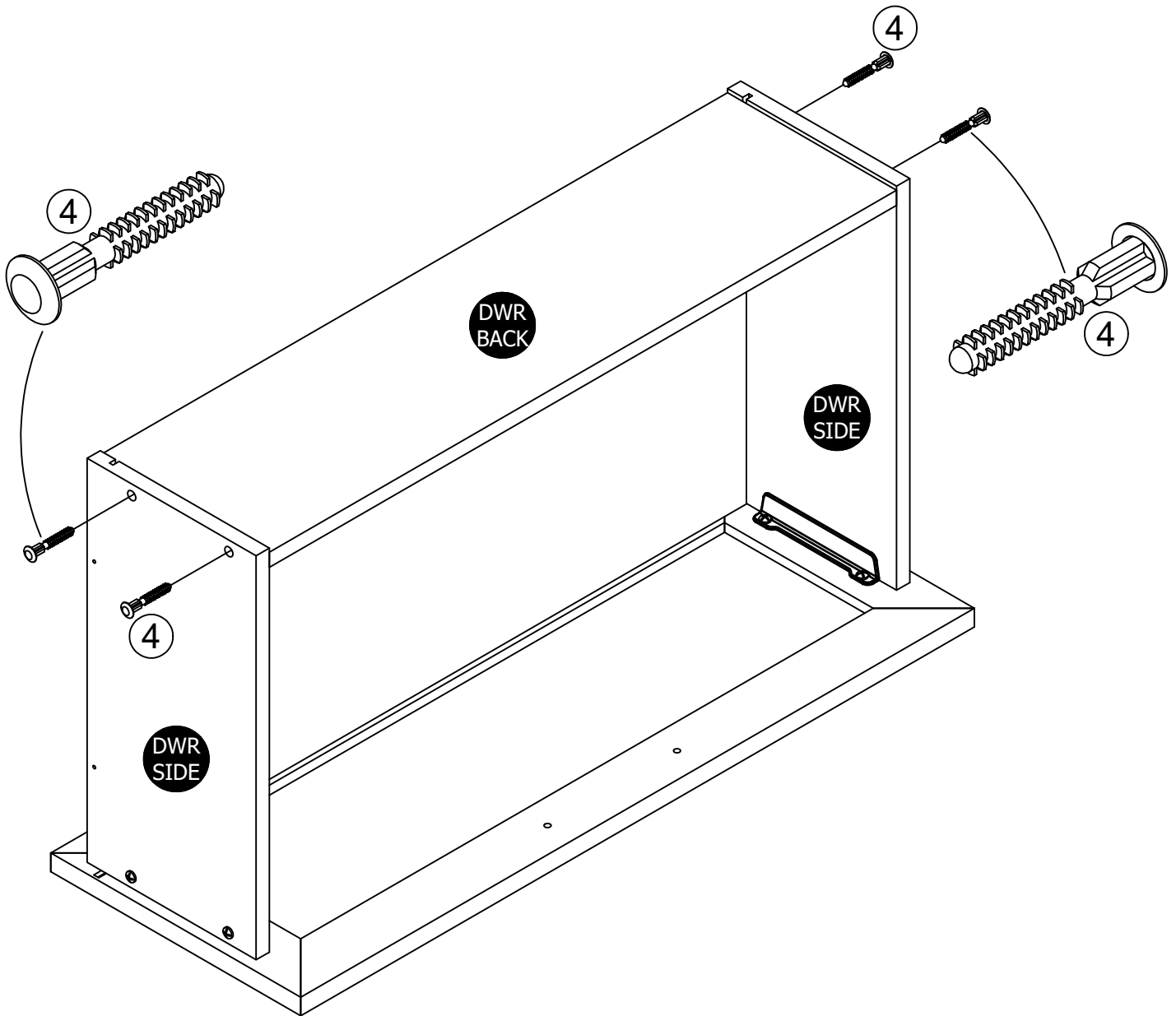

STEP 19

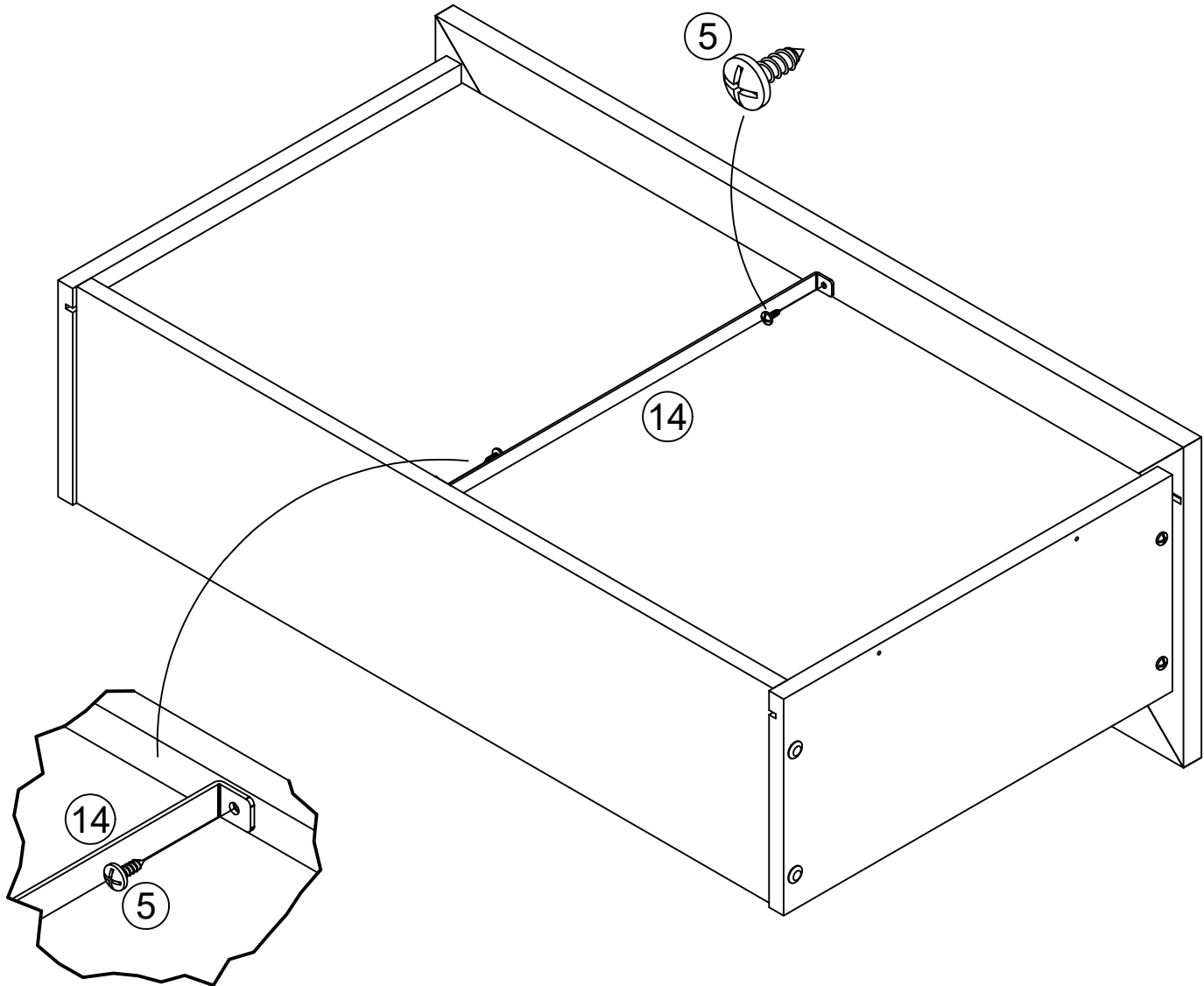
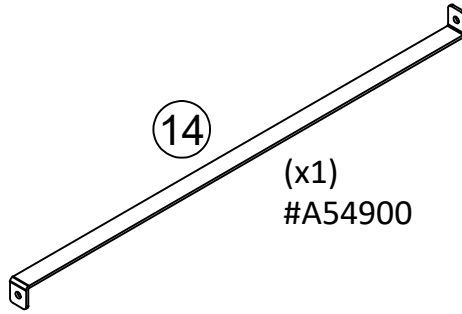
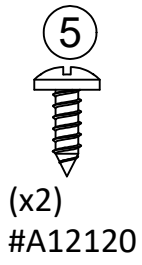
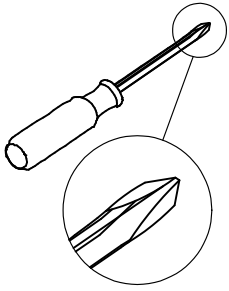

STEP 20

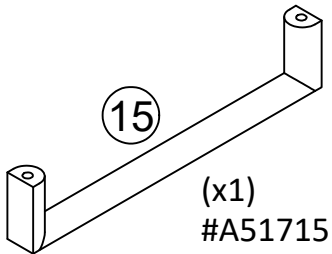
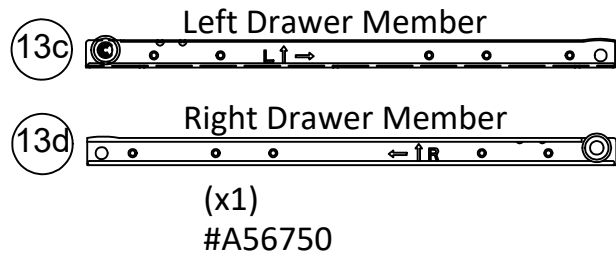
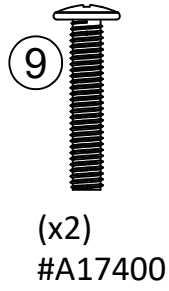
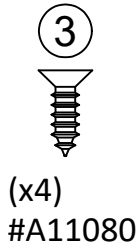
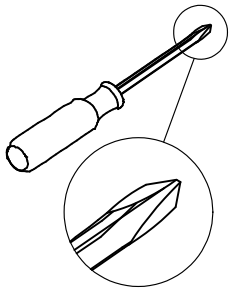

Attach the slides first and then the handles.

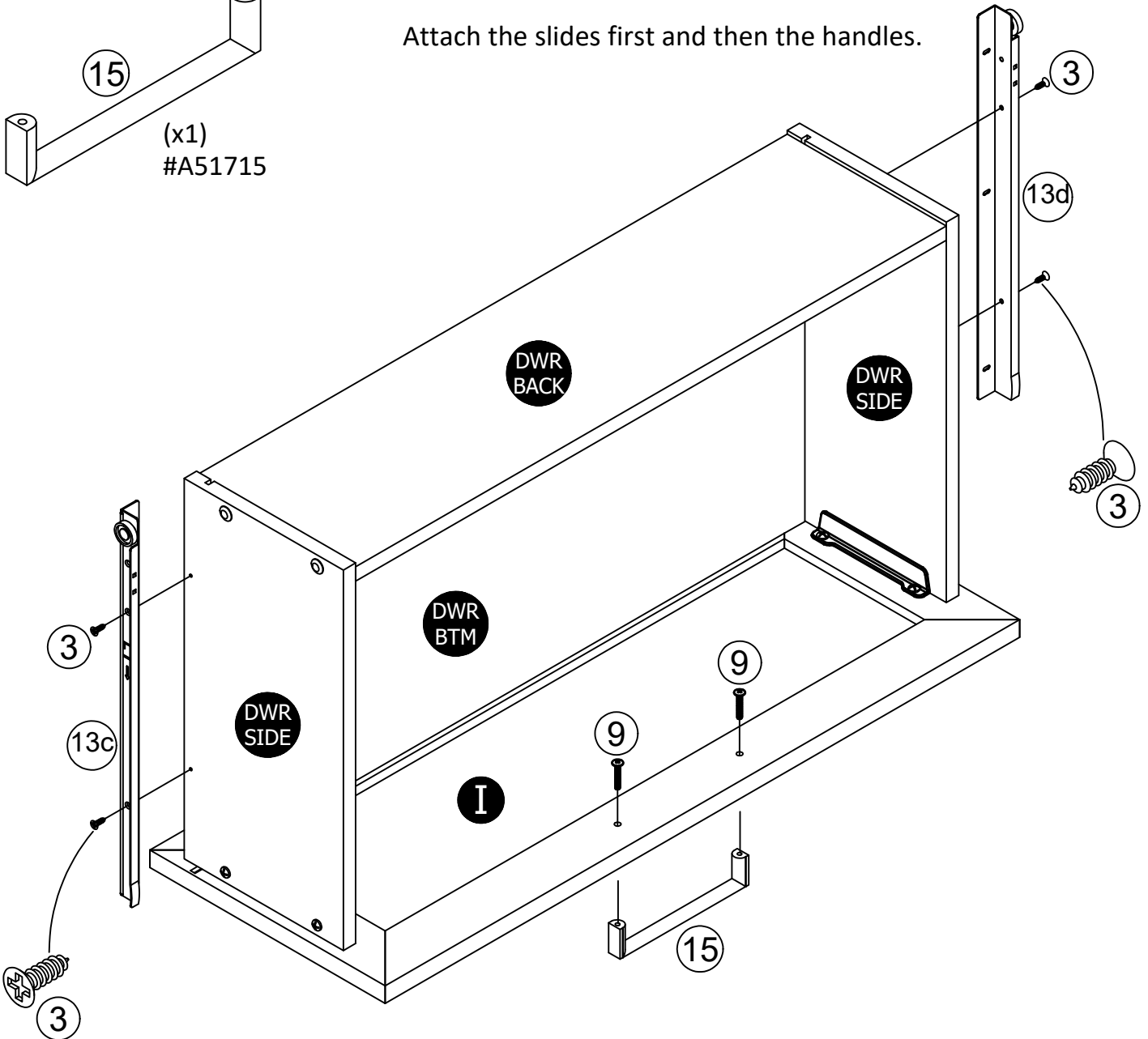

STEP 21

Note: The drawer bracket holes are slotted. Drawer fronts can be adjusted by loosening screws, making needed adjustments and retightening screws.

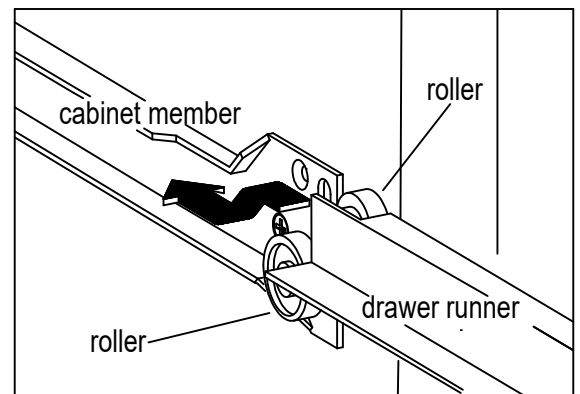
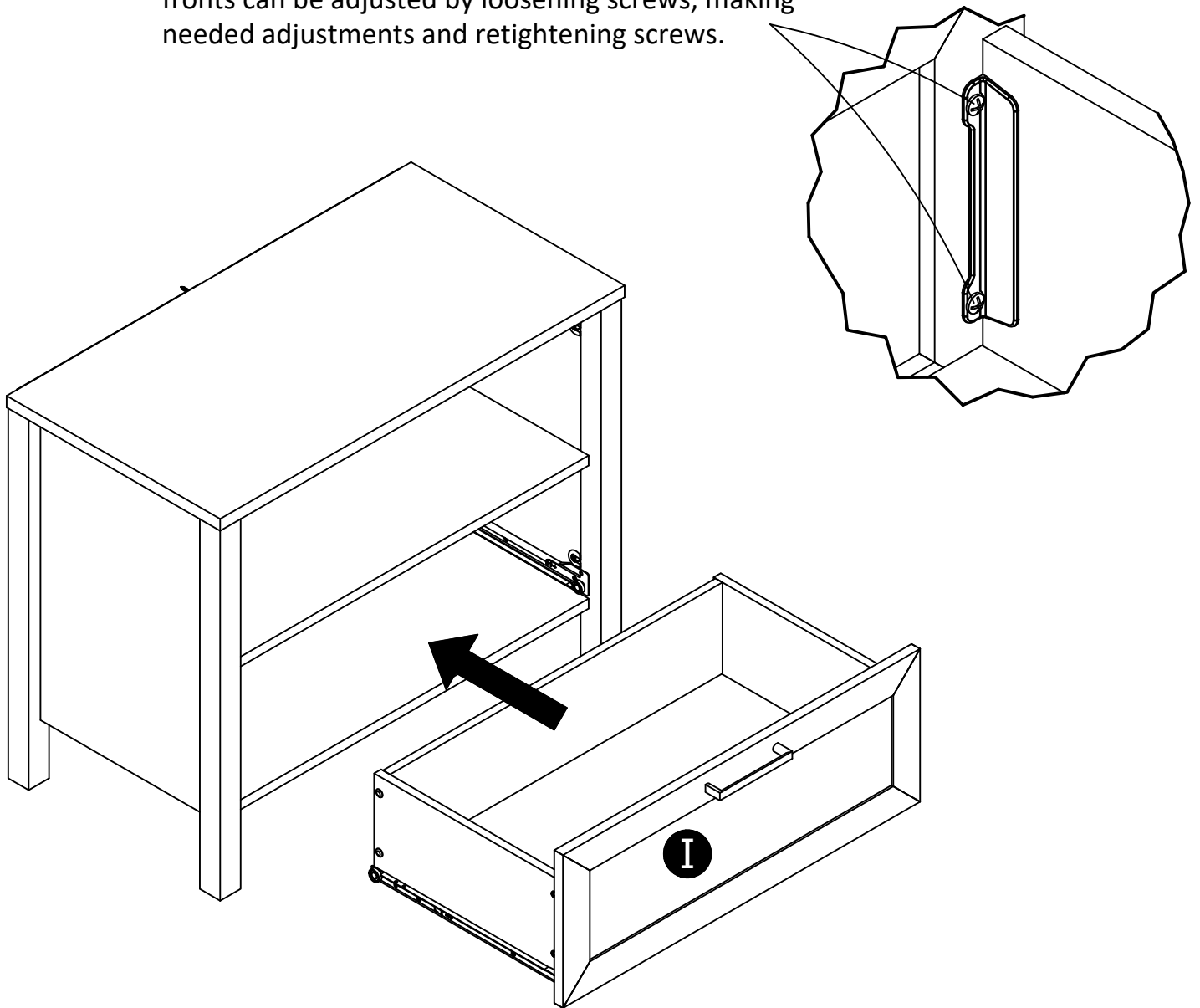

Maximum Loads

This unit has been designed to support the maximum loads shown. Exceeding these load limits could cause sagging, instability, product collapse, and/or serious injury.

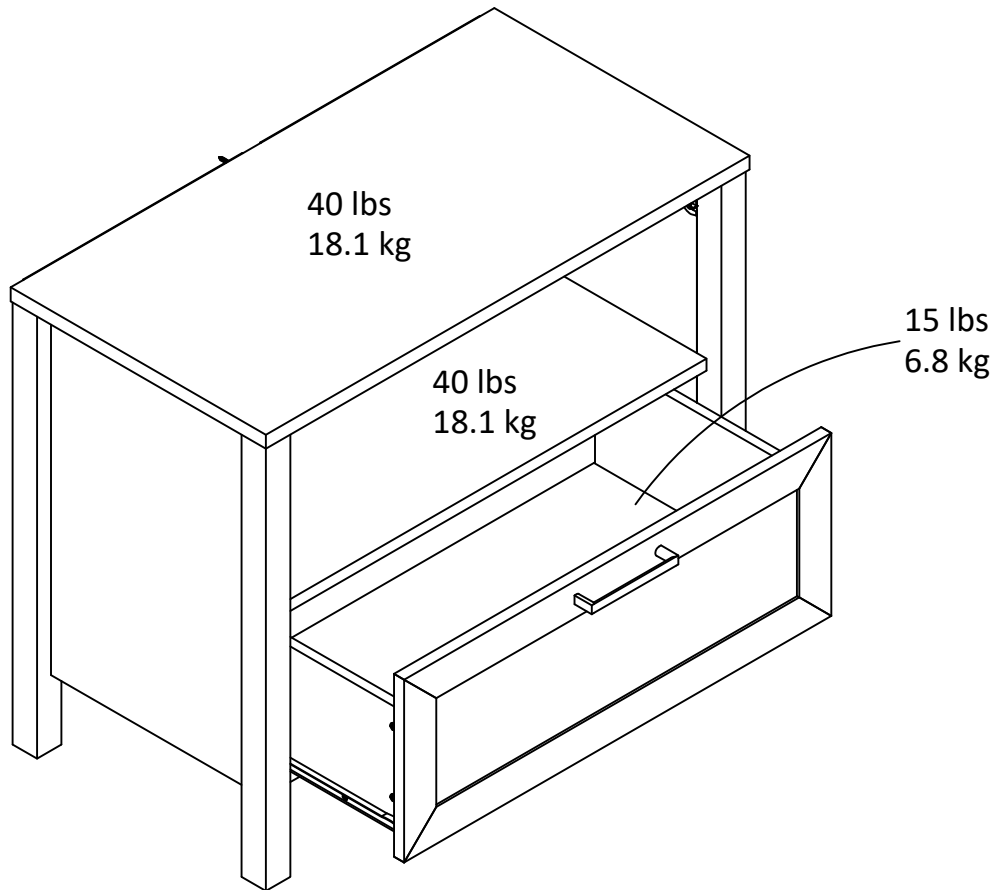

Warning: Risk of injury to persons - do not place a television on this furniture. This furniture is not approved for use with a television.

Certificate of Conformity

1. This certificate applies to the Dorel Home Furnishings, Inc. product identified by this instruction manual.
2. This certificate applies to compliance of this product with the CPSC Ban on Lead-Containing Paint (16 CFR 1303).
3. This product is distributed by: Dorel Home Furnishings, Inc.
410 East First Street South
Wright City, MO 63390
636-745-3351
4. Site of Manufacture: Tiffin OH
5. See front page of instruction manual for date of manufacture.

Register your product to receive the following:



- * New trend details - sneak peek on what's new
- * Surveys - have a voice within our community
- * Exclusive deals and discount codes
- * Quick and easy replacement part service

To register your product, visit ameriwoodhome.com

5 Star Rating



Visit your local retailer's website, rate your purchased product and leave us some feedback!

We would like to extend a big "Thank You" to all of our customers for taking the time to assemble this Ameriwood Home product, and to give us your valuable feedback.

*Thank
You!*

Español

Cubierta Delantera

Este libro de instrucciones contiene información **IMPORTANTE** de seguridad. Por favor lea y manténgalo para referencia en el futuro.

No Regrese este producto! Comuníquese con nuestro amistoso equipo de servicio al cliente para obtener ayuda.

Llamenos al: 1-800-489-3351 (Gratis) Lunes - Viernes 9am - 5pm CST

Visitar: www.ameriwoodhome.com

PRECAUCION

Este mueble puede volcarse y causar graves heridas y/o muerte.

Anclar el mueble a un poste de madera en la pared (si esto se requiere).

No Permita que los niños monten el mueble.

Mantenga los artículos más pesados en los cajones de abajo.

Consejos Útiles (página 2)

- Abra su artículo en el área donde usted planea utilizarlo para evitar levantar y moverlo menos
- Identificar, ordenar y contar las piezas antes de intentar ensamblar
- Las clavijas de compresión se golpean con un martillo
- Las diapositivas están marcadas con una R (derecha) y L (izquierda) para la colocación correcta
- Asegúrese de que siempre este el punto localizado en la parte superior de bloqueador de leva este volteado hacia borde exterior
- Utilizar todos los clavos para el panel de atrás y distribuirlos por igual
- El panel de atrás debe utilizarse para asegurarse de que la unidad quede fija y firme
- No use químicas fuertes ni limpiadores abrasivos en este artículo
- Nunca empuje, tire ni arrastre los muebles

Antes de Que Empieces (página 3)

- Lea cuidadosamente cada paso y siga el orden correcto

- Separar y contar todas sus piezas y hardware

- Dése suficiente espacio para el proceso de ensamble

- Tenga las siguientes herramientas: destornillador de cabeza plana, #2 cabeza Phillips

Destornillador y martillo

- Precaución: Si usa un taladro electrónico o un destornillador eléctrico para atornillar, por favor asegúrese que deje de atornillar cuando el tornillo este apretado. Fallar hacer esto puede causar barrer el tornillo.

Sistema de fijar el bloqueo de leva (página 3)

Esta sistema de fijar el bloqueo de leva sera usado en todo el proceso ensamble.

Página 4

Por favor, tenga en cuenta que:

Es posible que deba golpear ligeramente las clavijas de madera para insertarlas en los agujeros durante el proceso de ensamblaje.

Español

Página 10 / 13

Debe golpear el conector (7) con un martillo para insertarlo completamente. Asegúrese de que el conector esté en la posición que se indica antes de insertarlo en el orificio.

Página 21

¡IMPORTANTE! EL PANEL TRASERO ES UNA PARTE ESTRUCTURAL DE ESTA UNIDAD Y SE DEBE INSTALAR CORRECTAMENTE.

Con la ayuda de otra persona, voltee la unidad sobre su lado frontal. Coloque el panel trasero como se indica. Alinéelo de forma recta con los bordes exteriores. Fije el panel trasero a las patas traseras (G y H) con tornillos (5), pero no los apriete. Alinee el borde inferior del panel trasero con el borde inferior de la pieza inferior e introduzca los clavos directamente en los bordes traseros de la pieza superior (C) y la pieza inferior (D). Ahora apriete los tornillos (5).

Asegúrese de que la unidad quede cuadrada.

La distancia de una esquina a otra debe ser igual a la que se indica.

Asegúrese de que el borde del panel trasero esté nivelado con el borde inferior de la pieza inferior.

Página 22

Para mampostería, concreto u otros materiales de pared:

Consulte con su ferretería local los anclajes adecuados para fijar bien el soporte de seguridad.

IMPORTANTE: ESTA UNIDAD DEBE ESTAR ASEGURADA A LA PARED PARA EVITAR QUE SE LADEE. SIGA ESTAS INSTRUCCIONES PARA INSTALAR EL SOPORTE DE SEGURIDAD ANTILADEO INCLUIDO CON ESTE PRODUCTO.

OPCIÓN 1: Fijarlo a un montante (método preferido)

Con un detector de clavos, localice un montante en la pared. Coloque la unidad contra la pared y alinee el soporte de seguridad en esta zona. Para que sea más fácil introducir el tornillo, haga un orificio guía de 1/8" de diámetro (3 mm) que atraviese del soporte de seguridad al montante. Introduzca el tornillo por el soporte de seguridad hasta el montante. Apriete el tornillo que faltó ajustar en el paso 11.

OPCIÓN 2: Fijarlo a una placa de yeso

Coloque la unidad contra la pared en el lugar que desee, marque la pared con el soporte de seguridad y luego haga la unidad a un lado. Perfore un orificio de 3/16" de diámetro (5 mm) en la placa. Martille el anclaje de pared en el orificio hasta que quede nivelado. Vuelva a colocar la unidad en su lugar y fije el soporte de pared al anclaje de pared con el tornillo. Apriete el tornillo que faltó ajustar en el paso 11.

Español

Página 24

Asegúrese de que las ranuras de las piezas laterales del cajón estén alineadas con la ranura de la pieza frontal del cajón.

Página 26

Nota: debe golpear los tornillos de fijación (4) con un martillo para asegurar bien las piezas.

Página 28

Fije primero las correderas y luego las manijas.

Página 29

Nota: los soportes del cajón tienen orificios ranurados. Las piezas frontales de los cajones se pueden ajustar aflojando los tornillos, haciendo los ajustes necesarios y volviendo a apretar los tornillos.

Página 30

CARGA MAXIMA

Esta unidad ha sido diseñada para soportar la carga máxima anotada. El exceder estos límites puede causar inestabilidad, colapsarse y/o causar serias lesiones.

ADVERTENCIA: Riesgo de lesiones a las personas - no coloque un televisor sobre muebles. Este mueble no está aprobado para su uso con un televisor.

Página 31

Registre su producto para recibir lo siguiente:

- * Detalles de nuevas tendencias - Vistazo a lo nuevo
- * Encuestas - alec su voz entre su comunidad
- * Códigos de ofertas y descuentos exclusivos
- * Fácil y rápido servicio de partes de remplace

Para registrar su producto, visite ameriwoodhome.com

Clasificación de 5 estrellas

Visite el sitio web de su tienda local, califique su comprado y denos sus comentarios!

Nos gustaría enviar un gran "Agradecimiento" a todos nuestros clientes por tomarse el tiempo de ensamblar este producto de Ameriwood Home, y por darnos sus valiosos comentarios.

Gracias

Français

Couverture Avant

CE LIVRET D'INSTRUCTION CONTIENT DES INFORMATIONS **IMPORTANTES** SUR LA SÉCURITÉ. VEUILLEZ LIRE ET GARDER POUR UNE RÉFÉRENCE FUTURE

Ne retournez pas ce produit! Contactez notre équipe de service à la clientèle amicale d'abord pour obtenir de l'aide.

Appelez-nous: 1-800-489-3351 (sans frais) du Lundi au Vendredi de 9h à 17h Heure Centrale

Visitez: www.ameriwoodhome.com

ATTENTION

Le meuble peut basculer et causer des blessures graves ou la mort.

Ancrer le meuble à une planche murale dans le mur (si indiqué).

Ne laissez pas les enfants grimper sur le meuble.

Placez les articles lourds sur les étagères ou dans les tiroirs inférieurs.

Astuces Utiles (page 2)

- Ouvrez votre article dans la zone que vous prévoyez de le garder pour moins de levage lourd
- Identifier, trier et compter les pièces avant d'essayer d'assembler
- Les goujons de compression sont taraudés avec un Marteau
- Les glissières sont marquées d'un R (droit) et d'un L (gauche) pour un bon placement
- Assurez-vous toujours de faire face la pointe situé sur le haut de la Serrure de Came vers le bord extérieur
- Utiliser tous les clous fournis pour le panneau arrière et les répartir également
- Le panneau arrière doit être utilisé pour vous assurer que votre appareil est robuste
- N'utilisez pas de produits chimiques agressifs ou de nettoyeurs abrasifs sur cet appareil
- Ne jamais pousser, tirer, ou faire glisser votre meuble

Avant de Commencer (page 3)

- Lisez attentivement chaque étape et suivez le bon ordre
- Séparez et comptez toutes vos pièces et matériaux
- Donnez-vous suffisamment de place pour l'assemblage
- Avoir les outils suivants: tournevis à tête plate, #2 tournevis Phillips, et Marteau
- Attention: Si vous utilisez une perceuse électrique ou un tournevis électrique pour visser, veillez à ralentir et arrêter lorsque la vis est bien serrée. Le non-respect de cette consigne peut endommager la vis.

Système de Fixation de Came (page 3)

Ce Système de Fixation de Came sera utilisé tout au long de l'assemblage

Page 4

Veillez noter :

Vous devrez peut-être taper légèrement sur les chevilles en bois à insérer dans les trous pendant votre processus d'assemblage.

Français

Page 10 / 13

Vous devrez taper sur le connecteur (7) avec un marteau pour l'insérer complètement. Assurez-vous que le connecteur est positionné comme indiqué avant de le taper dans le trou.

Page 21

IMPORTANT! LE PANNEAU ARRIÈRE EST UNE PARTIE STRUCTURELLE DE CETTE UNITÉ ET DOIT ÊTRE INSTALLÉ CORRECTEMENT.

Avec l'aide d'une autre personne, retournez l'unité sur son côté avant. Positionnez le panneau arrière comme indiqué. Alignez le panneau avec les bords extérieurs. Fixez le panneau arrière aux pieds arrière (G&H) avec les vis (5) mais ne les serrez pas. Alignez le bord inférieur du panneau arrière avec le bord inférieur du bas et clouez-le directement dans les bords arrière du haut (C) et du bas (D). Serrez maintenant les vis (5).

Assurez-vous que l'unité est carrée.

La distance d'un coin à l'autre doit être égale, comme indiqué.

Veillez à ce que le bord du panneau arrière soit au même niveau que le bord inférieur du bas.

Page 22

Pour la maçonnerie, le béton ou autres matériaux pour les murs :

Consultez votre quincaillerie locale pour obtenir les ancrages appropriés afin de fixer solidement le support de sécurité.

IMPORTANT : CETTE UNITÉ DOIT ÊTRE FIXÉE AU MUR POUR ÉVITER QU'ELLE NE BASCULE. SUIVEZ CES INSTRUCTIONS POUR INSTALLER LE SUPPORT DE SÉCURITÉ ANTI-BASCULEMENT FOURNI AVEC CE PRODUIT.

OPTION 1 : Fixation dans un montant (méthode préférée)

À l'aide d'un détecteur de montant, localisez un montant dans le mur. Placez votre unité contre le mur, avec le support de sécurité aligné à cet endroit. Pour faciliter le vissage, vous pouvez percer un trou pilote de 3 mm de diamètre dans le montant, à travers le support de sécurité. Enfoncez la vis dans le montant en passant par le support de sécurité. Serrez la vis qui n'a pas été complètement serrée à l'étape 11.

OPTION 2 : Fixation dans une cloison sèche

Placez votre unité à l'endroit souhaité contre un mur et marquez le mur à travers le support de sécurité, puis mettez votre unité de côté. Percez un trou de 5 mm de diamètre dans le panneau mural. Tapez l'ancrage mural dans le trou jusqu'à ce qu'il soit à fleur. Mettez votre appareil en place et fixez le support mural à l'ancrage mural avec la vis. Serrez la vis qui n'a pas été complètement serrée à l'étape 11.

Français

Page 24

Veillez à ce que les rainures des côtés des tiroirs soient centrées avec la rainure des façades de tiroir.

Page 26

Remarque : Vous devrez taper sur les attaches (4) avec un marteau pour les fixer solidement.

Page 28

Fixez d'abord les glissières, puis les poignées.

Page 29

Remarque : Les trous des supports de tiroir sont fendus. Les façades des tiroirs peuvent être ajustées en desserrant les vis, en effectuant les réglages nécessaires et en resserrant les vis.

Page 30

CHARGES MAXIMALES

Ce meuble a été conçu pour supporter les charges maximales indiquées. En excédant ces limites de charge, le meuble pourrait devenir instable, s'effondrer, et/ou causer des blessures graves.

AVERTISSEMENT : Risque de blessure corporelle - ne pas placer une télévision sur ce meuble. Ce meuble n'est pas approuvé pour une utilisation avec une télévision.

Page 31

Enregistrez votre produit pour recevoir les éléments suivantes:

- * Détails sur les nouvelles tendances - un aperçu sur les nouveautés
- * Sondages - avoir une voix au sein de notre communauté
- * Offres exclusives et codes promo
- * Service de pièces de rechange rapide et facile

Pour enregistrer votre produit, visitez ameriwoodhome.com

5 Étoiles

Visitez le site Web de votre détaillant local, évaluez votre produit acheté et laissez-nous quelques commentaires !

Nous tenons à offrir un grand "Merci" à tous nos clients pour avoir pris le temps d'assembler ce produit "Ameriwood Home", et de nous donner vos commentaires précieux.

Merci